Installation, Operation, and Maintenance Manual

CEMLINE CORPORATION®

STEAM-TROL® Solid State Control Module and Electronic Control Valves



P. O. Box 55, Cheswick, PA, 15024
Phone: (724) 274-5430 • FAX (724) 274-5448
www.cemline.com

Table of Contents

<u>Section</u>	<u>Page</u>
Disclaimers	1
Contact Information	1
General Notes and Warnings	2
Notes	2
Warnings	2
Connection Electrical Power Source	3
The Controller Overview	4
Contractor Wiring	6
Ratings	6
Controller Screens.....	7
Setting the Controller.....	8
Home Screen.....	8
Main Menu Screen.....	9
Set Point Pressure (psig).....	10
High Pressure Cut Out	12
High and Low Pressure Differential	13
Timed Blowdown.....	13
Low Pressure Alarm	15
Control Valves	16
Control Output	17
Maximum Output	19
PID Gain Kp (Proportional).....	20
PID Gain Ki (Integral)	21
PID Gain Kd (Derivative).....	21
Remote Set Point	22
Level Control Type	24
Setting Pressure Sensor Range.....	25

Display Timeout	27
Installer Mode	28
Test Menu Options	30
Software Version	30
Test Timed Blow Down.....	31
Test Key	32
Factory Default	33
Configure MODBUS Communication	34
Setting the MODBUS (Address) User Number.....	34
Setting the MODBUS Baud Rate	35
Logo Control.....	36
Terminal Board Layout.....	38
Building Automation System Interface	39
Remote On-Off	39
Operating Pressure Read-Out	40
Remote Pressure Pressure Set Point	40
MODBUS	42
Wiring Diagram for Self-Contained Temperature Pilot Operated Control Valves	44
Wiring Diagram for Pneumatically Operated Control Valves.....	45
Wiring Diagram for Warren Controls with AmurAct Actuator (After August 2024)....	46
Wiring Diagram for Warren Controls with AmurAct Actuator (Before August 2024) .	47
Wiring Diagram for MXG and MFX Valves.....	48
Wiring Diagram for M2H and M3P Valves	49
Wiring Diagram for MVF Valves.....	50
MXG and MXF Valve Information	51
M3P and M2H Valve Information.....	53
MVF Valve Information	54
General Valve Information	56
Magnetic Coil Resistance Information	57
Warren Controls ARIA Actuator Valve Information	58

All trademarks in this manual are property of Cemline Corporation, unless otherwise noted or in any other way set forth as a third party rights. Unauthorized use of these trademarks, as well as the materials presented in this manual, is expressly prohibited and constitutes a violation of the intellectual property rights of Cemline Corporation.

Disclaimers

This Installation, Operation, and Maintenance Manual is intended to be as complete and up to date as possible. It covers the installation, operation, and maintenance procedures for CEMLINE CORPORATION's STEAM-TROL[®] control module. CEMLINE[®] reserves the right to update this manual and other product information concerning installation, operation, and/or maintenance, at any time and without obligation to notify product owners of such changes.

CEMLINE is not responsible for inaccuracies in specifications, procedures and/or the content of other product literature, supplied by the manufacturers of components used in CEMLINE STEAM-TROL control module. CEMLINE strives to use only the highest quality components; however, CEMLINE has no direct control over their manufacture, or their consistent quality.

CEMLINE is not responsible for injury to personnel or product damage due to the improper installation, operation, and/or maintenance of CEMLINE Electronic Controls. All installation, operation, and maintenance procedures should only be performed by trained/certified personnel. All personnel performing these procedures should completely and carefully read and understand all supplied materials before attempting the procedures. All personnel should pay strict attention to all Notes, Cautions, and Warnings that appear within the procedures detailed in this manual.

CEMLINE welcomes user input as to suggestions for product or manual improvement.

Contact Information

For information concerning warranties, or for questions pertaining to the installation, operation or maintenance of CEMLINE products, contact:

CEMLINE CORPORATION
P.O. Box 55
Cheswick, PA 15024

USA Phone: (724) 274-5430
USA Fax: (724) 274-5448
www.cemline.com

To order replacement parts, contact CEMLINE CORPORATION at the address listed above, or call toll free:

USA/Canada/Caribbean Phone: (800) 245-6268

Note: Please include the model and serial number of the unit for which the parts are being ordered. If ordering by phone, please have this information readily available.

General Notes and Warnings

Notes

- ❖ This manual is intended to cover installation, operation, and maintenance procedures for CEMLINE CORPORATION STEAM-TROL control module.

If questions are not answered by this manual, or if specific installation, operation, and/or - maintenance procedures are not clearly understood, contact CEMLINE CORPORATION for clarification before proceeding.
- ❖ All installation, operation, and maintenance procedures should be performed only by - experienced, trained and certified personnel. Personnel should be trained in and familiar with correct piping and electrical procedures and methods, and should be experienced in working with hot/boiler water systems and steam systems.
- ❖ CEMLINE CORPORATION STEAM-TROL control module and other electronic controls are designed for indoor use only, unless otherwise required by design specifications.
- ❖ If the unit is damaged during installation, operation, or maintenance, complete the following steps:
 1. Turn off and lock out the electric power supply to the unit in an approved manner.
 2. Turn off all incoming steam/hot water valves.
 3. Contact in-house maintenance personnel or CEMLINE CORPORATION for instructions.

Warnings

As with any piece of equipment that utilizes hot/boiler water or steam and electricity, **the potential exists for severe personal injury** if proper installation, operation, and maintenance procedures are not followed. Listed on the following pages are specific warnings pertaining to CEMLINE Electronic Controls. **All warnings should be carefully read and understood.** All precautions contained in the warnings should be carefully followed to reduce the chance of injury.

Note: Throughout this manual, warnings will be denoted by the symbol ▼ .

All documentation for each major component has been included with the unit. It is strongly recommended that each document be reviewed before attempting any installation, operation, or maintenance procedures.

The documentation for each major component may also contain warnings and cautions identified by the manufacturer of each component. These warnings and cautions may be specific for the particular component, and therefore not covered in this general Installation, Operation, and Maintenance Manual. They should also be carefully reviewed before attempting installation, operation, or maintenance procedures.

- ▼ The combination of electricity and water can pose a **very dangerous situation**. Assure that all power has been **shut off/disconnected and locked out** in an appropriate manner, before attempting any installation or maintenance procedures.
- ▼ Areas of potential danger:
 1. all electric power leads and connections;
 2. all hot/boiler water lines, steam lines, joints, valves, and relief valves; and
 3. all joints at valve, gauges, etc.
- ▼ Before attempting any installation, operation, or maintenance procedures pertaining to the unit.
 1. assure that the electric power supply has been turned off and locked out in an approved manner;
- ▼ Hot/boiler water and steam present a situation that can be very dangerous due to the fact it is under pressure and at very high temperatures. To avoid possible injury or death, use common sense and follow all accepted and recommended procedures when performing installation, operation, and maintenance procedures.

Connecting the Electric Power Source

- ▼ All installation procedures involving electric power connection should only be performed by trained, certified electricians.
- ▼ Hot/boiler water and steam present a situation that can be very dangerous because of the high temperatures and pressures. Use common sense and follow all accepted and recommended procedures when performing installation, operation, and maintenance procedures to avoid possible injury or death.
- ▼ The combination of electricity and water can pose a very dangerous situation. Assure that all power has been shut off/disconnected and locked out in an approved manner, before attempting any installation or maintenance procedures.

The CEMLINE Steam Generators have been wired during assembly. Connecting the electric power supply to the unit consists of connecting the correct voltage, phase, and amperage power leads to the terminal strip or circuit breaker. The exact voltage, phase, and amperage requirements for the unit can be determined from the rating plate affixed to the jacket of the unit, or from the Submittal Sheet and Wiring Diagrams supplied with the unit.

The Controller - Overview

Cemline STEAM-TROL control module is a solid state controller designed to control pressure, limit, water feed, alarm, and timed blowdown functions for Cemline unfired steam generators.

The STEAM-TROL is supplied with an LCD touch screen display. LED pilot lights are supplied to indicate On-Off, high pressure, low pressure, low water, high water, water feed, and blow down. The STEAM-TROL allows the owner to set pressure limits on the display screen. The STEAM-TROL has a flashing red alarm light and alarm horn with built in alarm silence relay. The STEAM-TROL is supplied with dry contact closure outputs to indicate to building automation control (BAC) Power on, Low water, High pressure, Water feed, High water, Low pressure and Blow down occurring. The control module allows the BAC to turn the Unfired Steam Generator on or off through a remote relay suitable for 24 VAc, 1 amp. The control module allows the BAC to remotely monitor the operating pressure. The control module is supplied with an on-off switch and is mounted in a NEMA 4 enclosure.

Built in remote start stop: This feature allows the Unfired Steam Generator to be started or stopped from a remote location. Typically this would be accomplished from the Building Automation Control (BAC). Requires a dry contact suitable for 24 VAc and 1 amp. Terminal P7 contacts 3 & 4 on the panel are where the BAC on-off is wired.

Built in On-Off Switch: Allows for local on-off and is convenient for service in the unlikely event service is required. This switch is mounted in the side of the panel.

Built in Alarm Horn: The alarm horn will sound and fault LED will light (blinking red) on low water or high pressure. If either high water or low pressure options are selected the alarm horn will also sound and the alarm light will light (blinking red) in the event of high water or low pressure. The STEAM-TROL also features an alarm silence relay which will silence the alarm but not the fault light when the generator is being serviced. When the fault is cleared both the alarm and fault light will automatically reset.

Built in timer for timed blow down: If the timed blowdown option is selected the time and duration of blow down can be easily selected in the STEAM-TROL.

Built in relay for water feed: the Cemline STEAM-TROL operates in conjunction with the level control to signal the feed water solenoid or feed water pump to maintain the correct water level in the unfired steam generator.

Built in operating pressure readout: The STEAM-TROL features an easy to read LED digital readout of the operating pressure.

Built in high pressure cut off and alarm: In the event of high pressure the STEAM-TROL will close the source steam or HTHW supply valve and sound an alarm.

Built in low water cut off and alarm: In the event of low water the STEAM-TROL will close the source steam or HTHW supply valve and sound an alarm.

Built in low pressure alarm: If activated, the STEAM-TROL will sound an alarm if a low pressure condition occurs.

Built in optional input / output.

Built in LED display of functions and alarms: The STEAM-TROL is designed for the user to tell at a glance how the system is operating. The built in LED displays make troubleshooting simple.

Function	LED Indicator 1	LED Indicator 2
Power ON	Green = Power On	Blank = No power
Low water	Green = Water level not low	Red = Low water
High pressure	Green = Normal pressure	Red = High pressure
Water feed	Green = Water feeding	Blank = Water not called for
High water	Green = Water level normal	Red = High water
Low pressure	Green = Pressure not low	Red = Low pressure
Blow down operating	Green=Blowdown occurring	Blank = No blowdown
Optional input/output		

Built in contacts to notify BAC (Building Automation Control) of functions and alarms: This control allows for simple and reliable interface from a remote location. The BAC can also start and stop the unfired steam generator.

Power ON
Low water
High water
Water feed
High pressure
Low pressure
Blow down operating
Optional input / output
Alarm
Operating pressure (via a 0-10 Vdc signal)

Contractor Wiring

All Power Connections should be performed by a trained , certified electrician. Be sure the factory supplied on-off switch is in the OFF position before connecting to building power.

Field wiring: Installer must run feed wires to terminals on panel mounted on-off disconnect switch and green ground wire to ground lug. *Units are normally wired for 120 volt single phase input.*

Warning: Before drilling hole in panel for conduit connection of power carefully open door and verify that nothing in panel will be interfered with. BE CAREFUL not to get any drill shavings or metal slug on board or transformer or disconnect switch.

Panel is normally factory shipped for 120 Volt/ 1 phase/60/50 Hz. If so desired 220/1/50 or 60 Hz power can be used. To convert to 220 volt input it is necessary to reconfigure the 24 volt output transformer. Below is the wiring diagram for 120 volt and 220 volt input.

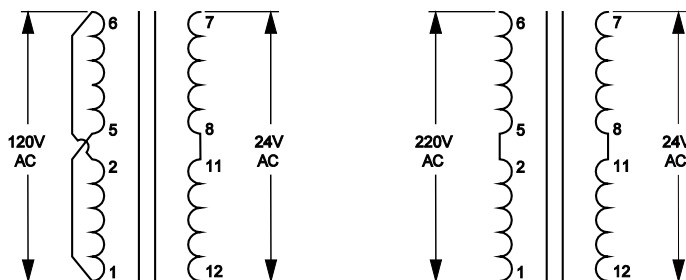

▼ **CAUTION: Before attempting to rewire the transformer be sure power coming to the unit is turned off and locked out in an approved manor.**

Ratings

Input: selectable 120/220 VAC – 50/60 Hz @ 120 Vac min 90 volt max 130 volt
Output Contacts: 1 amp at 24 Vac
Building Automation outputs: Dry contacts, NO .5 amp maximum, non inductive
Display: LED display with resolution of .3 % of scale
Available pressure sensor ranges: 0-30 PSI, 0 – 60 PSI, 0-150 PSI, and 0 - 300 PSI. Operating ambient temperature: Min 32 Deg F max 140 deg F
Operating Humidity: 5% to 95% relative humidity (RH) non condensing
Alarm approximately 103 db.
NEMA 4 enclosure

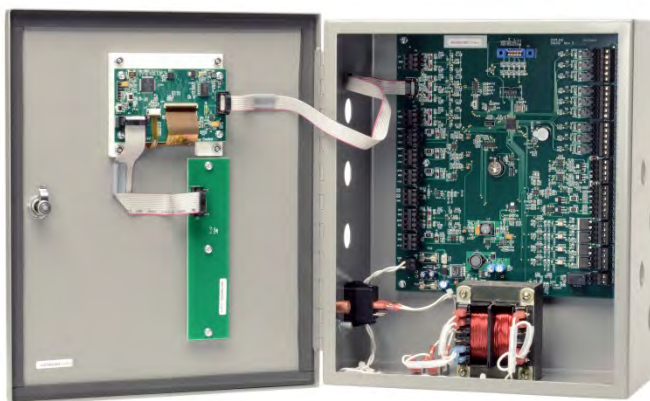

The Cemline STEAM-TROL is a self contained board and can not be field repaired. For a replacement board contact Cemline Corporation at the address shown on page one of this manual.

Controller Screens

Controller Home Screen:

The controller is supplied with an LCD touch screen. The MENU button in the lower right hand corner of the screen is touched in order to go to the main menu screen to set the controller.

In the event an alarm horn is going off touch the screen to silence the alarm horn.

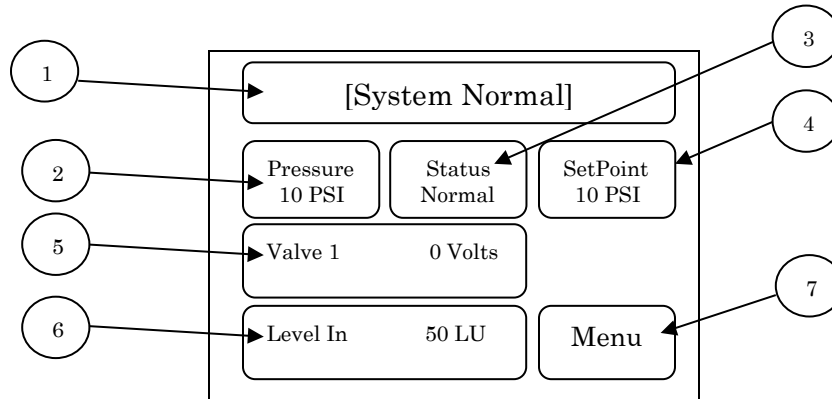

1. Top Banner: [System Normal] will indicate if the system is normal. If there is an alarm this area will indicate the type of alarm. Top Banner will indicate if using a Remote Set Point.
2. Pressure: This is the pressure of the steam in generator. Pressure is indicated in PSI.
3. Status: This will indicate if the status of the unit is in Normal or in Alarm state.
4. Set Point: This displays the set point of the unit in PSI.
5. Valve: This will indicated if one or two valves is being used with the controller. This will indicated the voltage between 0 – 10 VDC being supplied to the control valve.
6. Level: Level In is the level control indicator. When using a 4 ball float or a cast iron type float the approximate level will be displayed in Level Units (LU). When using an analog single ball float the Level In will be displayed in milliamps (between 4 – 20 mA). 4 mA will be indicated if the float is at the top of the level control and 20 mA will be indicated if the float is at the bottom of the level control. The Level Out will display the milliamps between 4-20 mA going out to the modulating feedwater valve.
7. Menu: This is the button that will allow the user to set the controller.

After 90 seconds in any screen "Home" screen will be displayed

Setting the Controller

Setting the Controller

The controller is supplied with an LCD touch screen display. The screen will display virtual buttons or selection choices on the screen that are pushed or selected to set the device. The function and settings are read on the LCD display. The sequence to access and change any screen is as follows:

1. Press “MENU” button to go to the the Main Menu screen.
2. In the Main Menu Screen select a setting by pressing the wording of the setting that will highlight the setting on the screen.
3. Press the SELECT button to go to the setting adjustment screen for the highlighted setting.
4. For settings requiring numeric values press the + / - keys to cycle through the values in an increasing or decreasing fashion until the desired setting is displayed on the screen.
5. For settings with specific options press the NEXT / PREV keys to cycle through the options until the desired option is highlighted on the screen.
6. Press the ACCEPT or SELECT key to store last screen setting into memory and return the controller to the Main Menu screen.

Instructions for Setting Each Screen:

Home Screen

This is the screen which should be displayed during normal operation:

Home

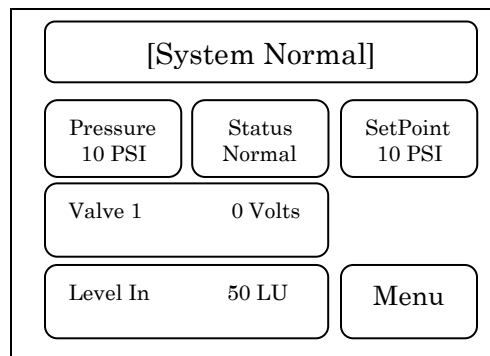

TOP BANNER: [System Normal] will indicate if the system is normal. If there is an alarm this area will indicate the type of alarm. Top Banner will indicate if using a Remote Set Point.

STATUS can be either NORMAL or ALARM. The mode will read normal in normal operation and alarm if any alarm condition occurs. If an alarm condition is cleared the mode will switch back to normal reading.

Pressure PSI: This is the pressure of the generated steam.

MENU: This button is pushed by the user to adjust settings of the controller.

Valve: This will indicated if one or two valves is being used with the controller. The valve display area will indicate the voltage between 0 – 10 VDC which is being supplied to the control valve. Below are examples of the valve screen with one valve or two valve options.

One Valve



Two Valves

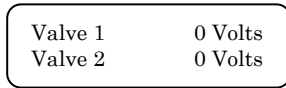

Level: Level In is the level control indicator. When using a 4 ball float or a cast iron type float the approximate level will be displayed in Level Units (LU). When using an analog single ball float the Level In will be displayed in milliamps (between 4 – 20 mA). 4 mA will be indicated if the float is at the top of the level control and 20 mA will be indicated if the float is at the bottom of the level control. The Level Out will display the milliamps between 4-20 mA going out to the modulating feedwater valve.

4-Ball / Cast Iron

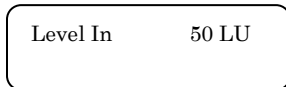

Analog

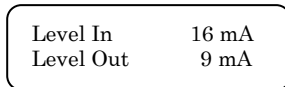

Main Menu Screen

When the user pushes the Menu button the Main Menu screen will be displayed. The Main Menu screen(s) shows a list of options that can be selected. There are six (6) options displayed at a time on the screen. There are a total of 22 menu options. In order to cycle forward through the list of available options the user must push the NEXT button. In order to cycle backward through the list of available options the user must push the PREV button. There is a two step process for selecting an option, the user must first highlight the option by touching it on the screen and then push the SELECT button.

Main Menu Screen Options 1 - 6:

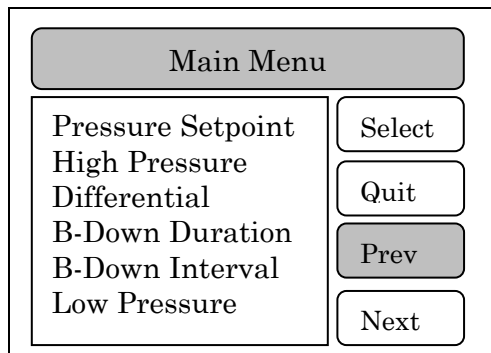

Main Menu Screen Options 7- 12:

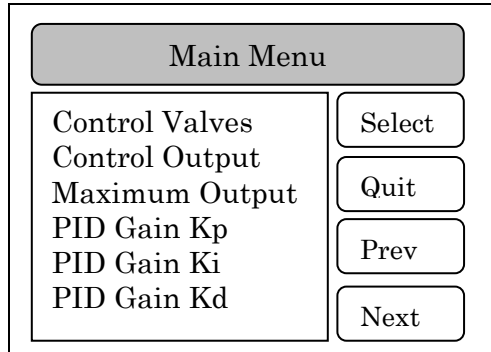

Main Menu Screen Options 13- 18:

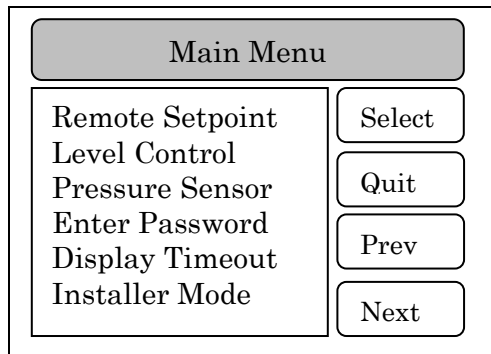

Main Menu Screen Options 19- 22:

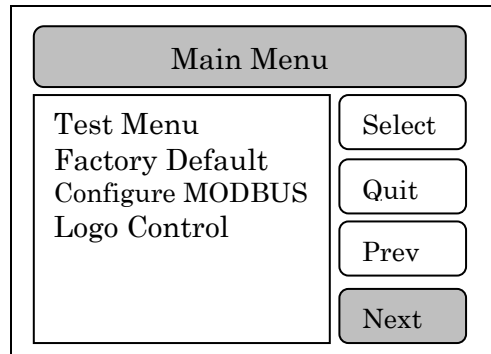

Set Point Pressure (psig)

This is the operating pressure set point of the unfired steam generator. If the steam generator was supplied with either a pneumatic control valve with an I-P transducer or an electronic control valve the pressure set point of the steam generator will be selected using the STEAM-TROL. This feature is not functional when using a pilot operated valve with self-contained pressure pilot.

To set the operating pressure set point:

1. Highlight Pressure Set Point on the Main Menu Screen and press the SELECT Button:

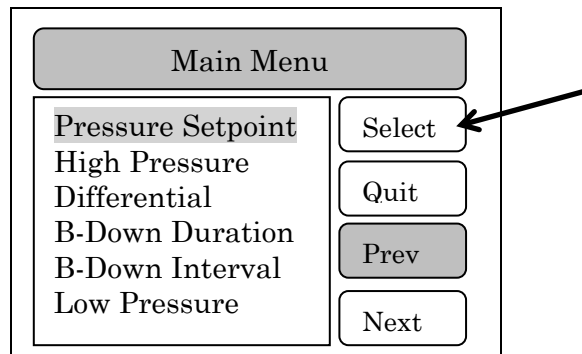

2. The following screen will appear:

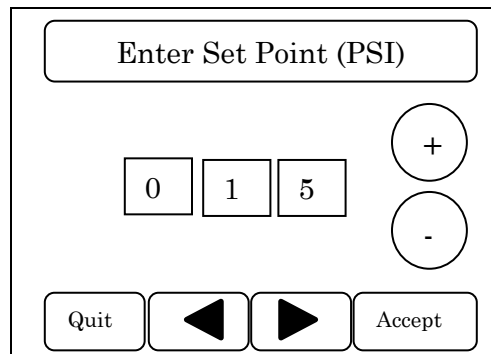

3. Press “+” key to change pressure setting in an increasing direction or press “-” key to change the pressure setting in a decreasing direction until the desired operating pressure appears on the screen. The set point pressure is adjustable between 0 – 30 PSI, 0 – 60 PSI, 0 – 150 PSI, or 0 – 300 PSI depending upon the range of the pressure sensor supplied in 1 PSI increments. The default value of the operating pressure set point is based upon the design requirements of the unit ordered.

NOTE: THE MAXIMUM SETTING IS LIMITED BY THE RANGE OF THE PRESSURE SENSOR. The operating pressure setting should be set lower 10-20% than the high pressure setting. The high pressure setting should be set lower than the relieving pressure the ASME relief valve supplied with the generator. The pressure rating of the relief valve is labeled on the relief valve body.

4. Press ACCEPT key to place setting in memory and to return to Main Menu screen.

High Pressure Cut Out

This is the high pressure limit which is set 10-20% higher than the desired operating pressure. When the high pressure cut out pressure is reached the controller will cause the main control valve to close.

- ▼ **CAUTION:** If using a pilot operated control valve the operating pressure is set by the control valve pressure pilot, see the IOM manual of the pilot control valve for setting the operating pressure of the pressure pilot.

To set the High Pressure Cut Out:

1. Highlight High Pressure on the Main Menu Screen and press the SELECT Button.

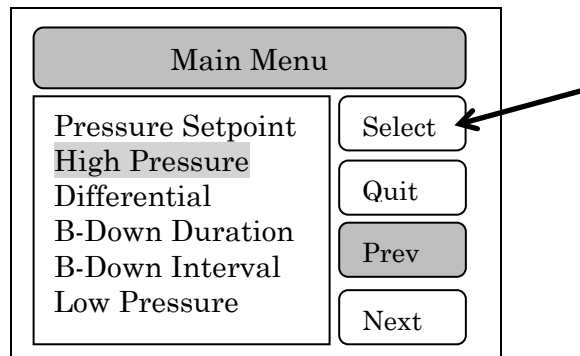

2. The following screen will appear:

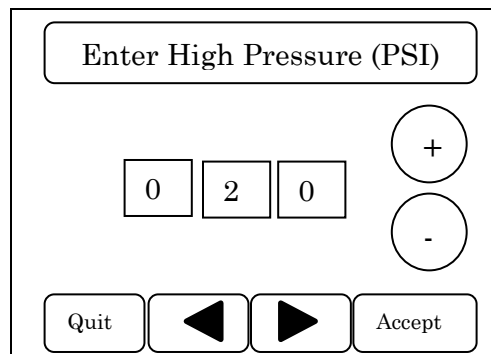

3. Press the + / - keys to scroll through the pressure settings until the desired pressure setting appears on the screen. The settings are in 1 psi increments. **NOTE: THE MAXIMUM SETTING IS LIMITED BY THE RANGE OF THE PRESSURE SENSOR. The high pressure setting should be set lower than the relieving pressure the ASME relief valve supplied with the generator. The pressure rating of the relief valve is labeled on the relief valve body.**
4. Press ACCEPT key to place the setting in memory and return to the Main Menu screen.

High and Low Pressure Reset Differential

This is the pressure differential from the set point at which the high or low pressure will reset. Normally it is set at 2 psi but can be set from 1 to 10 psi. NOTE: There is only one differential setting and it will be the same for both high and low pressure.

To set the pressure differential:

1. Highlight Differential on the Main Menu Screen and press the SELECT button.

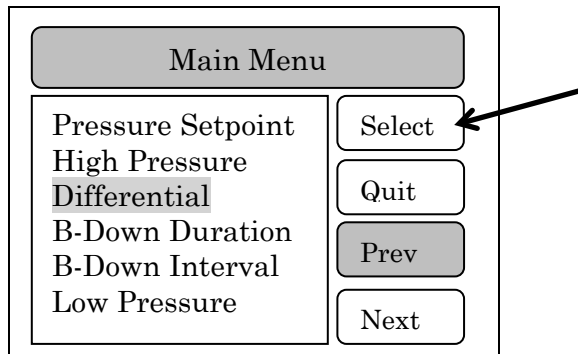

The following screen will appear:

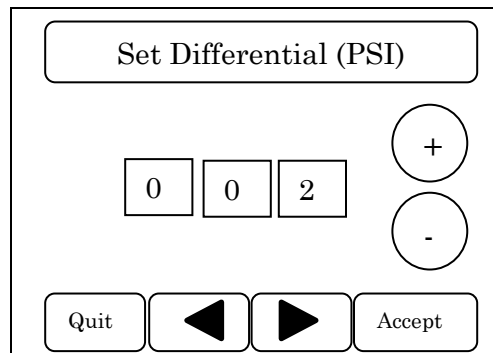

2. Press the + / - key(s) to scroll through the psi settings until the desired psi differential is displayed.. The range is 1-10 psi.
3. Press the ACCEPT key to place setting in memory and return to the Main Menu screen.

Timed Blow Down

If Timed Blow Down is an option which was purchased the duration and interval of the blow down can be selected. Duration is the length of time the blow down occurs (in seconds) and interval is the number of hours between blow downs.

To set the duration of blow down:

1. Highlight the B-Down Duration on the Main Menu Screen and press the SELECT button.

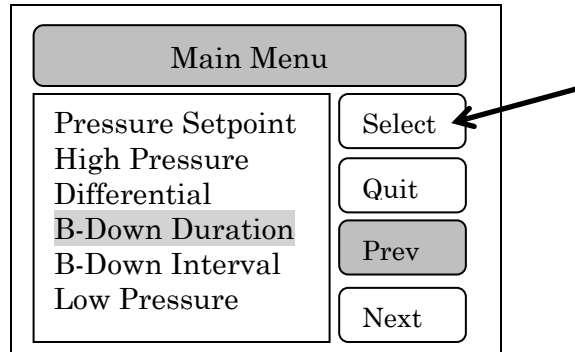

2. The following screen will appear:

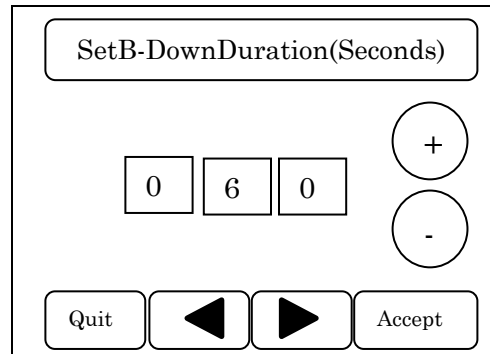

3. Press the + / - keys to scroll through the various seconds settings until the desired number of seconds of blow down appears on the screen. The seconds will read 0-250 seconds in 1 second increments.
4. Press ACCEPT key to place setting in memory and to return to Main Menu.
NOTE: To disable the timed blow down set duration to zero (0)

To set the interval:

1. Highlight the B-Interval on the Main Menu Screen and press SELECT button.

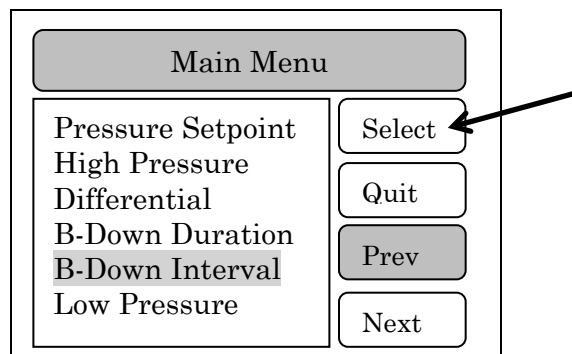

2. The following screen will appear.

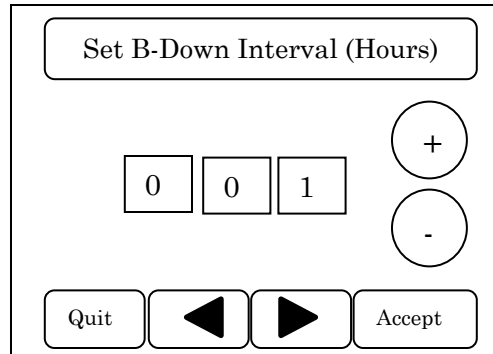

3. Press the + / - key(s) to scroll through the various hour settings until the desired number of hours between blow downs appears on the screen. The hours will read 0-160 hours in one hour increments.
4. Press SELECT key to place the setting in memory and return to home screen.

NOTE: To disable the timed blow down set interval to zero (0)

Low Pressure Alarm

If desired, a low pressure alarm can be set. This will alarm if the generated steam pressure falls below the low pressure setting.

To set the low pressure alarm:

1. Highlight Low Pressure on the Main Menu screen and press the SELECT button.

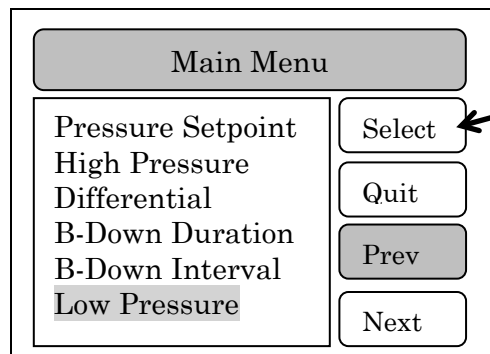

2. The following screen will appear:

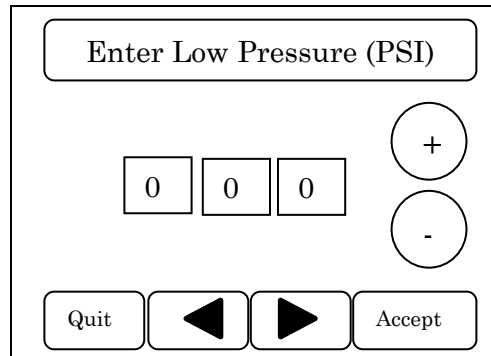

3. Press the + / - key(s) to scroll through the pressure settings until the desired low pressure setting appears on the screen.. The settings from 0-20 psi are in 1 psi increments. The maximum low pressure setting is equal to the high pressure setting set on screen 4.
4. Press the ACCEPT key to place setting in memory and return to home screen.

NOTE: To disable the low pressure alarm set the pressure to zero (0).

Control Valves

If desired the control module can be used to control two control valves set up in a 1/3 – 2/3 piping configuration.

To set the control valve option:

1. Press the NEXT key one (1) time and until Control Valves are displayed on the Main Menu.
2. Highlight Control Valves on the Main Menu screen and press the SELECT button.

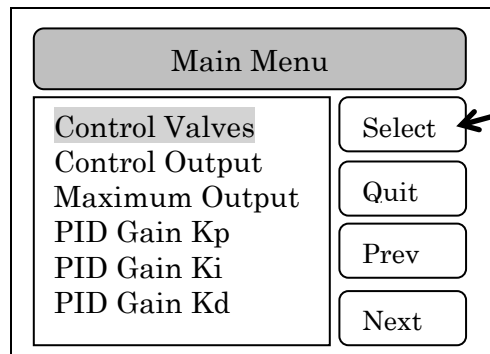

3. The following screen will appear:

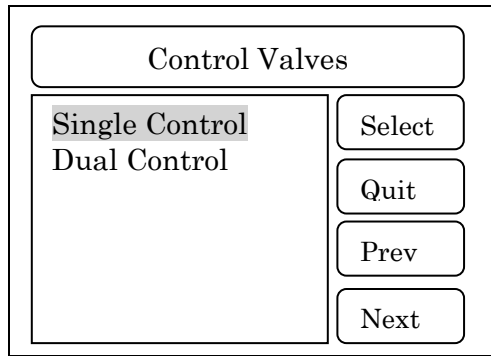

4. Highlight the desired Control Valve option. The control valve choices are “Single Control” when one control valve is being utilized or “Dual Control” when two control valves are being utilized.
5. Press SELECT key to place setting in memory and return to Main Menu screen.

Control Output

The STEAM-TROL has four output settings options. The output setting options are 0 – 10, 2 – 10, AIR VALVE, or a PILOT VALVE. The 0-10 setting will output a 0-10 VDC control output signal to the control valve, the 2 –10 setting will output a 2 -10 VDC control output signal to the control valve, and the AIR VALVE setting will output a 1.5 – 7.5 VDC control output signal to an electronic- to- pneumatic transducer. The electronic-to-pneumatic transducer converts the input voltage (1.5 to 7.5 VDC) to an output 3-15 psig air signal to the air operated control valve. The PILOT VALVE uses an externally mounted pressure pilot for modulating the control valve. When in PILOT VALVE mode the PID control / functionality of the STEAM-TROL is disabled.

- ▼ **CAUTION: DO NOT set the Control Output to 2 – 10 VDC or AIR VALVE setting for a control valve that operates on a 0 – 10 VDC control signal. This will prevent the control valve from closing as the STEAM-TROL will output a MINIMUM of 2 or 1.5 VDC. This will cause improper operation of the unit, with the potential for DANGER by causing alarms and solenoid valves to go off.**
- ▼ **THE VALVES DESCRIBED IN THIS MANUAL ON PAGES 46 – 54 REQUIRE A 0 –10 VDC CONTROL SIGNAL. THESE VALVES ARE MANUFACTURED BY SIEMENS BUILDING CONTROLS.**
- ▼ **WARREN CONTROLS AMURACT ACTUATOR REQUIRES 2 - 10 VDC CONTROL SIGNAL.**
- ▼ **AIR OPERATED CONTROL VALVES USE THE AIR VALVE SETTING. THE ELECTRONIC-TO-PNEUMATIC TRANSDUCER REQUIRES 1.5 – 7.5 VDC INPUT CONTROL SIGNAL TO PRODUCE A 3 – 15 PSIG OUTPUT AIR SIGNAL TO THE CONTROL VALVE.**
- ▼ **WHEN SELECTING THE PILOT VALVE OPTION THE P-I-D FUNCTIONALITY OF THE STEAM-TROL IS DISABLED.**

- ▼ **CAUTION: DO NOT set the “Control Output” to 0 – 10 VDC or AIR VALVE setting for a control valve that operates on a 2 – 10 VDC control signal. This will cause improper operation of the unit, with the potential for DANGER by causing alarms and solenoid valves to go off.**

It is extremely important that the control signal of the control valve supplied and the Control Output listed in the STEAM-TROL be the same. The steam generator is factory shipped with the Control Output properly set for the supplied control valve’s actuator.

To set the control output:

1. Press NEXT key one (1) time until Control Output is displayed on the Main Menu.
2. Highlight Control Output on the Main Menu screen and press the SELECT button.

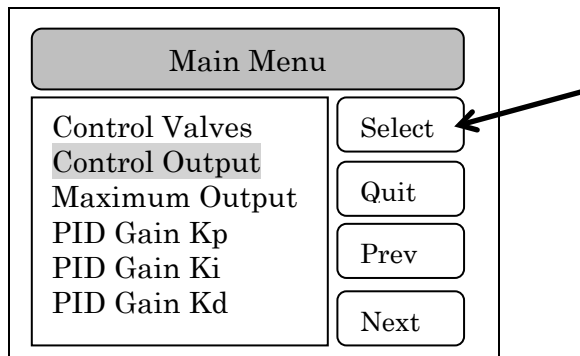

3. The following screen will appear:

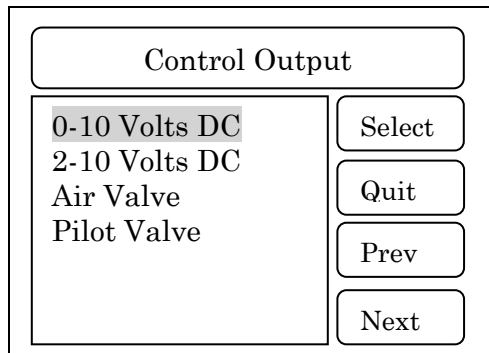

4. Verify that the Control Output listed on the screen and control valve’s required control signal supplied on the steam generator are the same. IF AND ONLY IF the control valve’s required signal is different than the “Control Output’s” screen setting should the screen setting be changed. Highlight the desired Control Output option. The Control Output choices are “0 –10 VDC” when the control valve requires a 0 – 10 VDC control signal , “2 – 10 VDC” when the control valve requires a 2 – 10 VDC control signal, “AIR VALVE” when using an air operated control valve, or “PILOT VALVE” when using a pilot operated control valve.

5. Press the SELECT key to place the setting in memory and return to the Main Menu screen.

Maximum Output

The STEAM-TROL can be adjusted to limit the maximum output voltage being sent to the control valve. The maximum output setting can be set as 10, 9, 8, 7, 6, or 5 VDC. The maximum output setting is used to limit the maximum stroke of the control valve. The maximum output adjustment is only available when the Control Signal is set to 0 – 10 VDC or 2 – 10 VDC.

The steam generator is factory shipped with the Maximum Output set for 10.

To set the maximum output:

1. Press MENU key one (1) time until Maximum Output is displayed on the Main Menu:
2. Highlight Maximum Output on the Main Menu screen and press the SELECT Button.

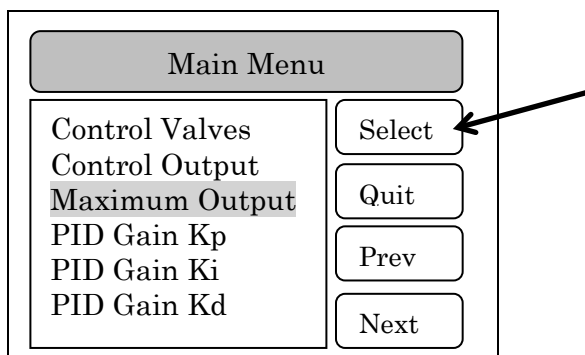

3. The following screen will appear:

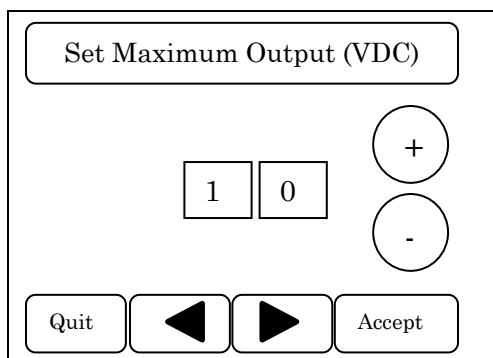

4. Press “+” key to change control output setting in an increasing direction or press “-” key to change the control output setting in a decreasing direction until the desired maximum control output appears on the screen. The range is 10 - 5.
5. Press ACCEPT key to place the setting in memory and return to the Main Menu screen.

Setting PID Gain Kp (Proportional)

The operating controls are factory preset for optimal control of the steam generator. The Kp (Proportional) is used to handle the present. Kp (proportional) is a constant used to send a signal to the output. The proportional control with a set point of 15 PSI and a proportional band of 2 would have a 100% output at 13 PSI, 50% output at 14 PSI and 25% output at 14.5 PSI. The default value of the Kp (proportional) is 2 (PSI). The Kp (Proportional) setting of the controller can be determined and if necessary changed as follows:

To set the PID gain Kp:

1. Press NEXT key one (1) times until PID Gain Kp is displayed on the Main Menu.
2. Highlight PID Gain Kp on the Main Menu screen and press the SELECT button.

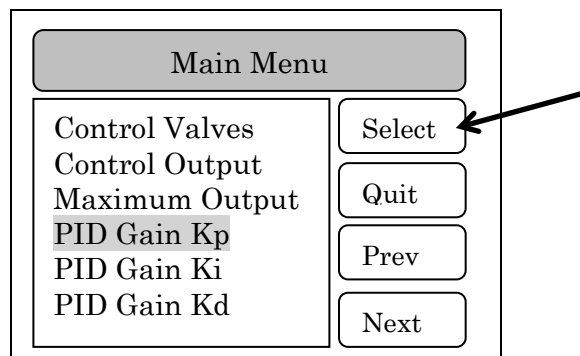

3. The following screen will appear:

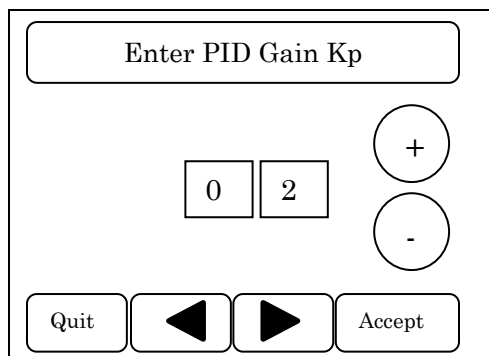

4. Press “+” key to change the Gain Kp setting in an increasing direction or press “-” key to change the Gain Kp setting in a decreasing direction until the desired PID Gain Kp appears on the screen. The range is 0-30 (PSI).
5. Press ACCEPT key to place the setting in memory and return to the Main Menu screen.

Setting PID Gain Ki (Integral)

The operating controls are factory preset for optimal control of the steam generator. The Ki (Integral) measures error over a short period of time to a constant used to send a signal to the output. The default value of the Ki (integral) is 0. The Ki (integral) setting of the controller can be determined and if necessary changed as follows:

To set the PID gain Ki:

1. Press NEXT key one (1) times until PID Gain Ki is displayed on the Main Menu.
2. Highlight PID Gain Ki on the Main Menu screen and press the SELECT button.

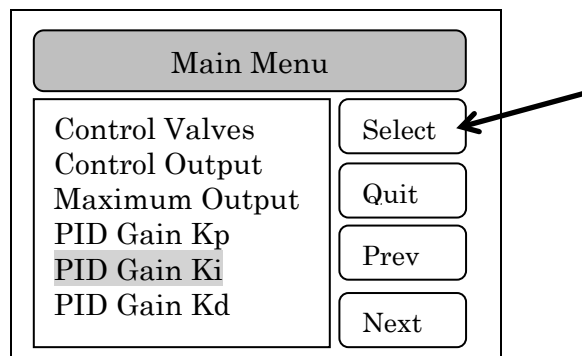

3. The following screen will appear:

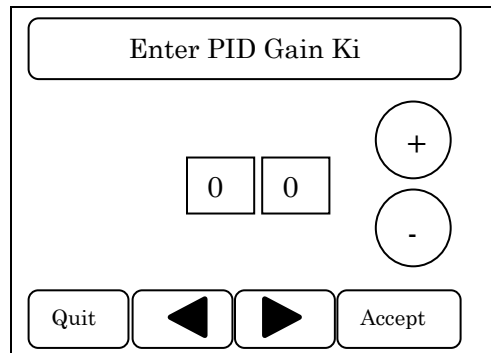

4. Press “+” key to change Gain Ki setting in an increasing direction or press “-” key to change the Gain Ki setting in a decreasing direction until the desired setting appears on the screen. The range is 0-30.
5. Press ACCEPT key to place the setting in memory and return to the Main Menu screen.

Setting PID Gain Kd (Derivative)

The operating controls are factory preset for optimal control of the steam generator. The Kd (derivative) measures error over a short period of time to a constant used to send a signal to the output. The default value of the Kd (derivative) is 0. The Kd (derivative) setting of the controller can be determined and if necessary changed as follows:

To set the PID gain Kd:

1. Press NEXT key one (1) times until PID Gain Kd is displayed on the Main Menu.
2. Highlight PID Gain Ki on the Main Menu screen and press the SELECT button.

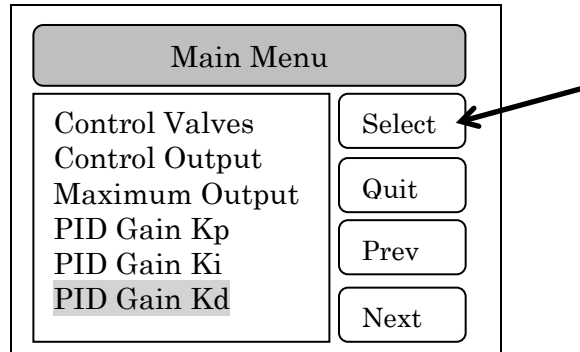

3. The following screen will appear:

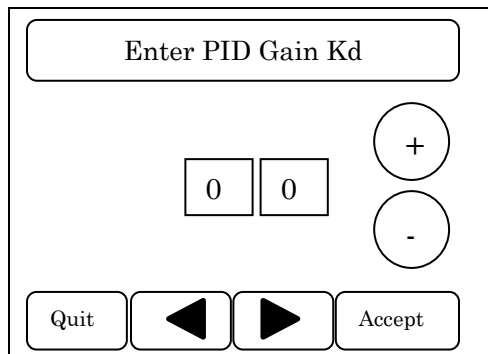

4. Press “+” key to change Gain Kd setting in an increasing direction or press “-” key to change the Gain Kd setting in a decreasing direction until the desired setting appears on the screen. The range is 0-30.
5. Press ACCEPT key to place the setting in memory and return to the Main Menu screen.

Remote Set Point

The STEAM-TROL can operate with a remote pressure set point. The remote pressure set point allows the Building Automation System (BAS) to supply a constant 4 – 20 mA signal to the controller.

- ▼ **CAUTION: When using the remote set point DO NOT set the operating pressure greater than the high limit settings. This will cause improper operation of the unit, with the potential for DANGER by causing alarms to go off and solenoids to close.**

- ▼ **CAUTION:** When using the remote set point **DO NOT** set the operating pressure greater than the relieving pressure the ASME relief valve supplied with the generator. The pressure rating of the relief valve is labeled on the relief valve body. high limit settings. This will cause improper operation of the unit, with the potential for **DANGER** by causing alarms to go off, solenoids to close, and the relief valve to open.
- ▼ **CAUTION:** Once the Remote Control is Enabled the local setting is no longer used unless the Remote Control has been Disabled.

The remote pressure set point of the pressure of the steam generator can be set between different ranges depending upon the pressure sensor used on the unfired steam generator. Cemline offers four possible pressure sensor ranges: 0 – 30, 0 – 60, 0 – 150, and 0 – 300 psi. When using 0 and 30 PSI using a 4 – 20 mA signal whereby 4 mA = 0 PSI and 20 mA = 30 PSI. See the table below for all pressure sensors and the equivalent 4 – 20 mA input settings.

Pressure Sensor	4 mA	20 mA
0 – 30 PSI	0	30
0 – 50 PSI	0	50
0 – 60 PSI	0	60
0 – 100 PSI	0	100
0 - 150 PSI	0	150
0 – 200 PSI	0	200

To set the remote set point:

1. Press NEXT key two (2) times until Remote Setpoint is displayed on the Main Menu.
2. Highlight Remote Setpoint on the Main Menu screen and press the SELECT button.

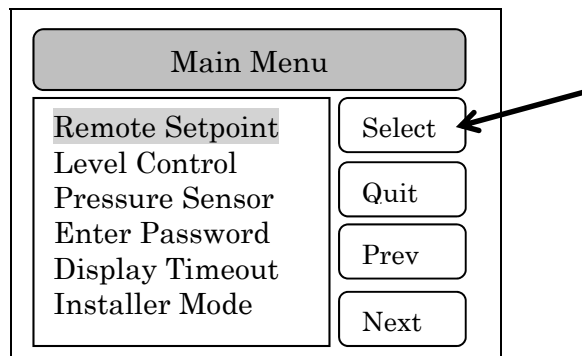

3. The following screen will appear:

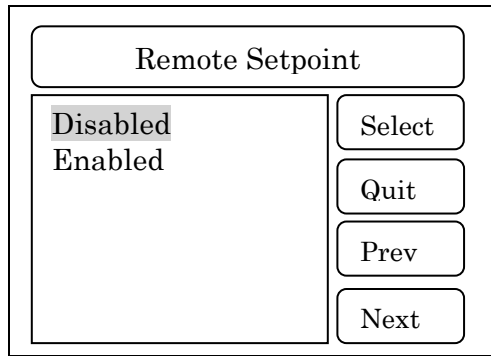

4. Highlight the desired Remote Setpoint option. The Remote Control choices are “Disabled” when the STEAM-TROL local pressure setting (Setpoint PSI) is being utilized or “Enabled” when a remote pressure set point via a 4-20 mA input signal is being utilized.

5. Press SELECT key to place the setting in memory and return to the Main Menu screen.

Level Control Type

There are three types of level controllers, which may be supplied with the Unfired Steam Generator. The first type is a 4 ball float assembly type mounted in a stainless steel body with a shape as shown below. This is 4 Level Type. The second type is a one ball float type with multiple switches in a cast iron body with a shape as shown below. This is 2 Level Type. The third type is a single ball float mounted in a stainless steel body with a shape as shown below. The single ball float provides a 4 – 20 mA signal of the level. This is the Analog Type.

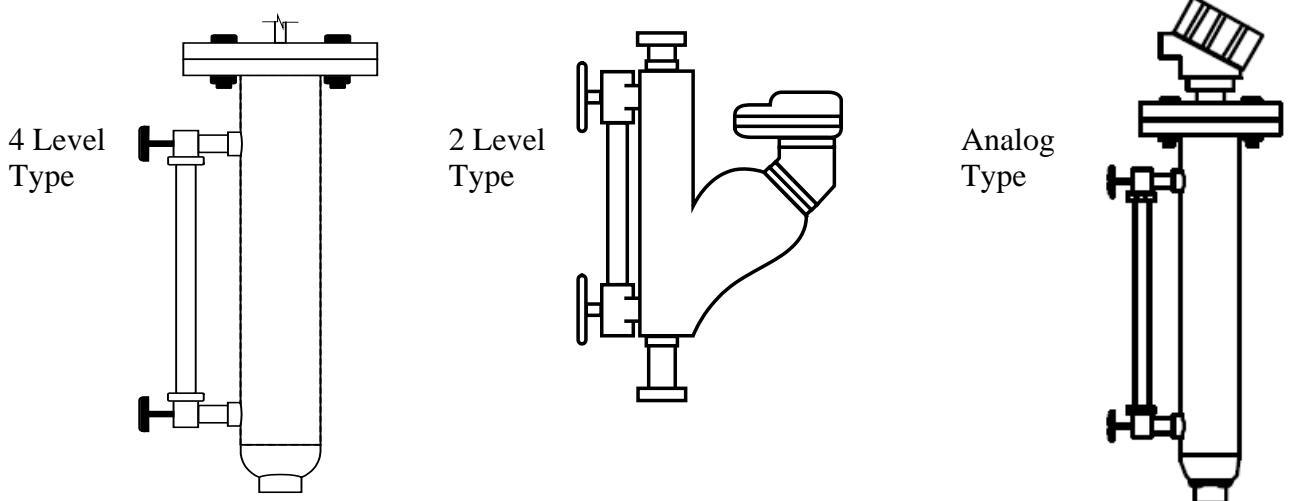

It is extremely important that the type of level control supplied and type listed in the STEAM-TROL be the same. The generator is factory shipped with matched types.

To set the level control type:

1. Press NEXT key two (2) times until Level Control is displayed on the Main Menu.
2. Highlight Level Control on the Main Menu screen and press the SELECT button.

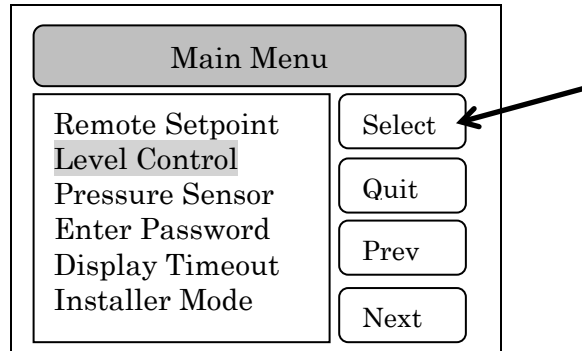

3. The following screen will appear:

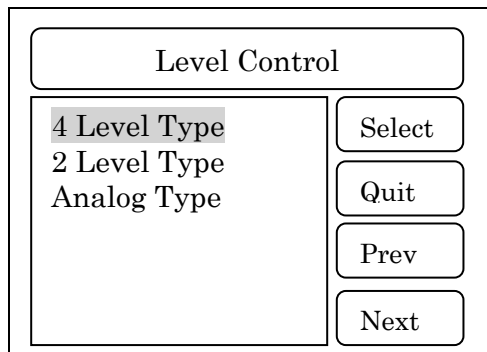

4. Verify that the type listed on screen and type supplied on Unfired Steam Generator are the same. IF AND ONLY IF the type of level control is different than the screen setting should the screen setting be changed. To change the screen setting press and highlight the type required.
5. If both types match press the SELECT key to place the setting in memory and return to the home screen

Setting Pressure Sensor Range

The pressure sensor supplied with the Unfired Steam Generator will have a specific range, normally 0-30 psi or 0-60 psi or 0-150 psi or 0-300 psi. **It is extremely important that the range of the pressure sensor and the range listed in the solid state controller be the same range.** The generator is factory shipped with matched ranges. The range of the sensor will be printed on the body of the sensor. The range of the controller can be determined and if necessary changed as follows:

To set the pressure sensor range:

1. Press NEXT key two (2) times until Pressure Sensor is displayed on the Main Menu.
2. Highlight Pressure Sensor on the Main Menu screen and press the SELECT button.

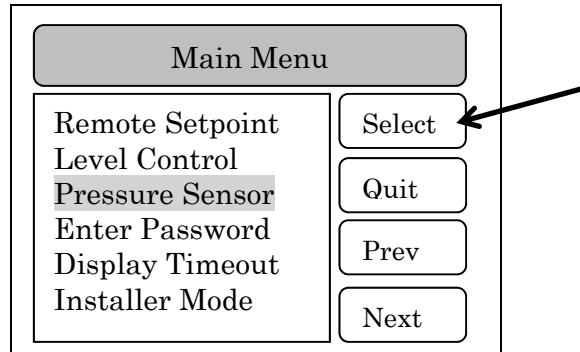

3. Press the SELECT key and the screen will read:

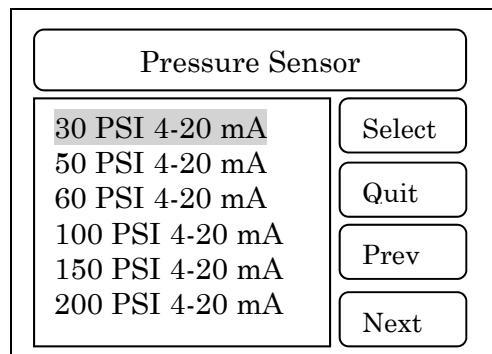

4. Verify that the psi range shown is equal to the range of the supplied sensor. The range shown on screen is the upper end of the range. 0-30 will appear as 30 on the screen, 0-60 will appear as 60 on the screen, etc. IF AND ONLY IF the range of the sensor is different than the screen setting should the screen setting be changed. To change the screen setting press NEXT key to change control valve setting in an increasing direction or press PREV key to change the Pressure Sensor Setting in a decreasing direction until the desired control valve setting is highlighted on the screen. When the desired pressure range appears on the screen verify that this matches the pressure of the sensor.
5. If both pressures match press the SELECT key to place the setting in memory and return to Main Menu screen

Enter Password

The STEAM-TROL is supplied with a password protection that is required to be entered in order to change the level control and pressure sensor settings.

To enter the password:

1. Press NEXT key two (2) times until Enter Password is displayed on the Main Menu.
2. Highlight Pressure Sensor on the Main Menu screen and press the SELECT button.

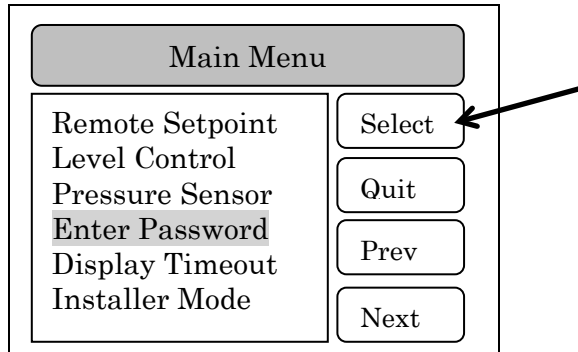

3. The following screen will appear:

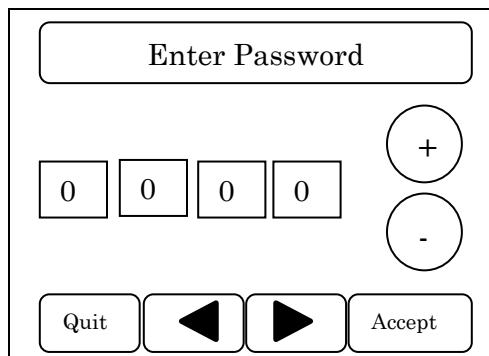

4. There are four values that need to be entered. Touch the screen in the box on the value that is to be altered. Press “+” key to change password setting in an increasing direction or press “-” key to change the password setting in a decreasing direction until the desired setting appears on the screen. Do this for all four values to until the passcode is properly selected. You will need to contact your local Cemline representative or the factory at 1-800-245-6268 for the passcode.
5. Once the proper passcode is displayed, press the SELECT key to place the setting in memory and return to Main Menu screen

Display Timeout

The display on the STEAM-TROL can be set to turn off in a screen saver/power save mode. This mode is similar to that of a screen saver on a computer. If an alarm occurs while the display is off the display will come turn back on.

To set the display timeout:

1. Press NEXT key two (2) times until Display Timeout is displayed on the Main Menu.

2. Highlight Display Timeout on the Main Menu screen and press the SELECT button.

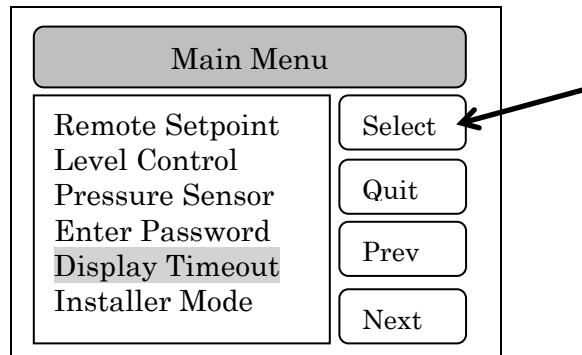

3. The following screen will appear:

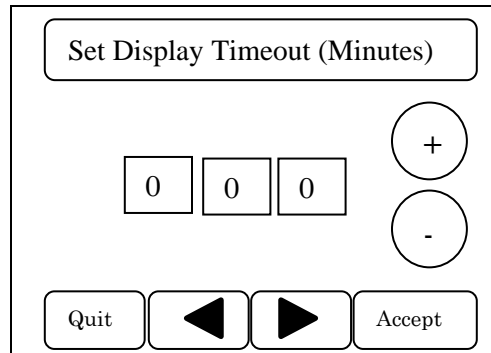

4. Press “+” key to change Display Timeout setting in an increasing direction or press “-” key to change the Display Timeout setting in a decreasing direction until the desired setting appears on the screen. The range is 0-300 minutes.
5. Press ACCEPT key to place the setting in memory and return to the Main Menu screen.

Installer Mode

The installer mode if enabled will remove the display of some of the items in the main menu. These items will not be accessible while the installer mode is enabled.

To set the installer mode:

1. Press NEXT key two (2) times until Installer Mode is displayed on the Main Menu.
2. Highlight Display Timeout on the Main Menu screen and press the SELECT button.

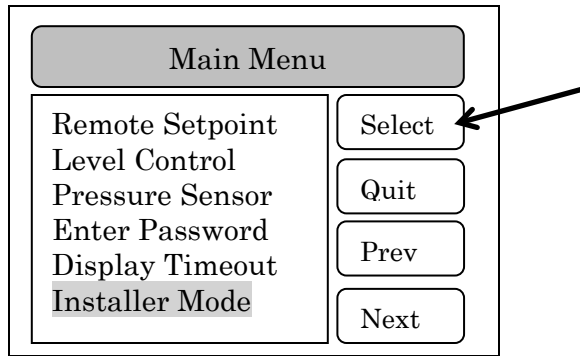

3. The following screen will appear:

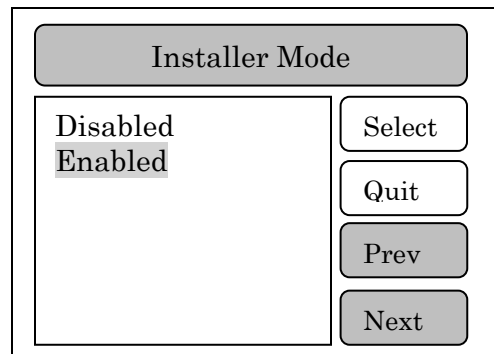

4. Highlight the desired Installer Mode. The Installer Mode choices are “Disabled” when all of the menu items will be displayed or “ Enabled” when some of the menu items will not be displayed in the main menu. When the Installer Mode is “Disabled” the Main Menu options 7 -12 are hidden. While in the “Disabled” Mode the user will not see the options for Control Valves, Control Output, Maximum Output, PID Gain Kp, PID Gain Ki, and PID Gain Kd.

When Installer Mode is Disabled Main Menu Screen Options 7- 12 (below) will not be displayed:

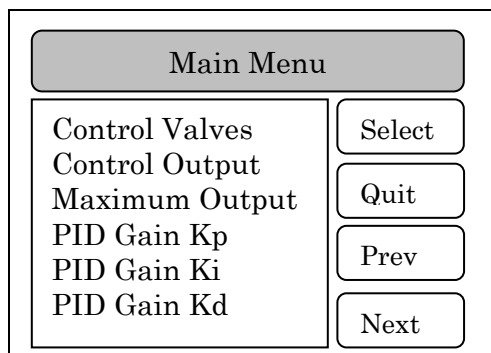

5. Press SELECT key to place the setting in memory and return to the Main Menu screen.

Test Menu Options

There are three (3) submenu items in the Test Menu option. They are Software Version, Timed Blowdown, and Test Key. To access any of these three items the user must go to the Test Menu screen first.

Software Version

This screen lists the version of the controller. When contacting the factory about the controller be sure to mention the version.

To view the software version:

1. Press NEXT key three (3) times until Test Menu is displayed on the Main Menu.
2. Highlight Test Menu on the Main Menu screen and press the SELECT button.

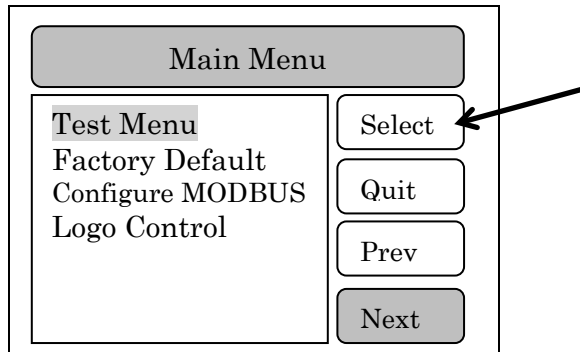

3. The Test Menu screen will appear:
4. Highlight Software Version on the Test Menu screen and press the SELECT button.

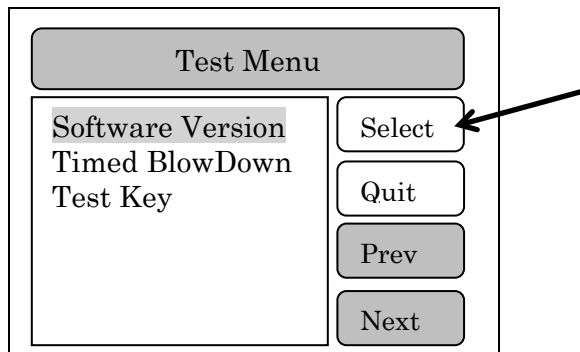

5. The following screen will appear:

```
>System Information
>Version 02.10
>UpTime 608:32:09
```

6. After 5 seconds the controller will automatically return to the Main Menu screen.

Test Timed Blow Down

This option allows the user to test the timed blow down to verify that the timed blow down solenoid is opening. When this option is selected timed blow down solenoid will be energized and open for 15 seconds. Also, the timed blow down LED will light green while the timed blow down solenoid is opened.

To test the timed blow down:

1. Press NEXT key three (3) times until Test Menu is displayed on the Main Menu.
2. Highlight Test Menu on the Main Menu screen and press the SELECT button.

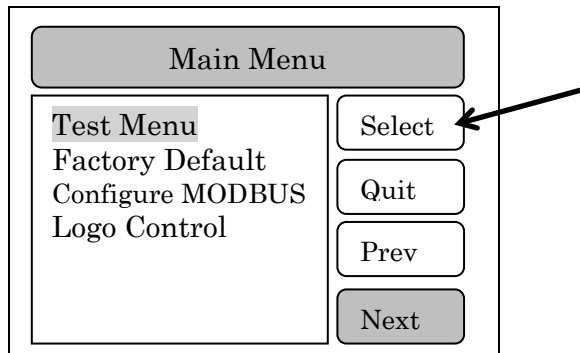

3. The Test Menu screen will appear:
4. Highlight Software Version on the Test Menu screen and press the SELECT button.

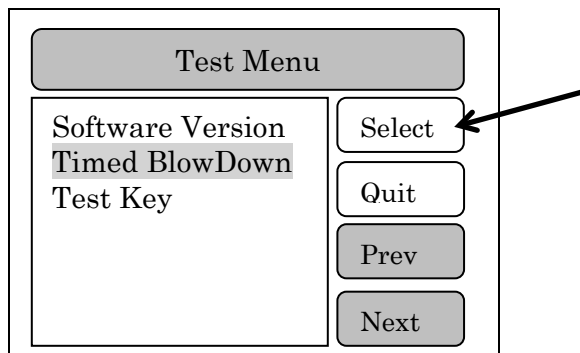

5. The following screen will appear:

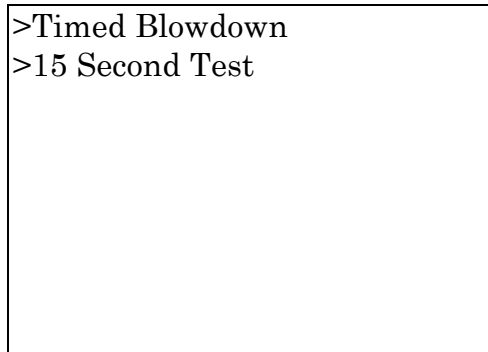

>Timed Blowdown
>15 Second Test

6. After 15 seconds of the Timed Blow Down light on and solenoid energized and open, the controller will automatically return to the Main Menu screen. The Timed Blow Down solenoid will de-energize and close after 15 seconds and the light will turn off or be in a blank state.

Test Key

The Test Key is used for factory testing and are not field useable.

To view the test key:

1. Press NEXT key three (3) times until Test Menu is displayed on the Main Menu.
2. Highlight Test Menu on the Main Menu screen and press the SELECT button.

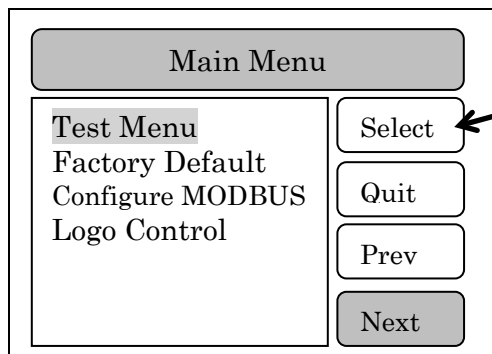

3. The Test Menu screen will appear:
4. Highlight Test Key on the Test Menu screen and press the SELECT button.

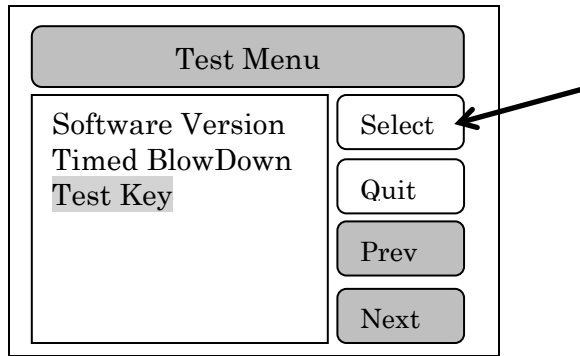

5. The following screen will appear:

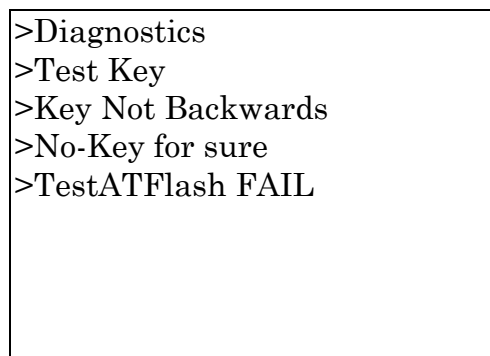

6. After 5 seconds the controller will automatically return to the Main Menu screen.

Factory Default

The Factory Default is used for factory testing and are not field useable. To go to “home” screen press Alarm Silence.

To view the factory default:

1. Press NEXT key three (3) times until Factory Default is displayed on the Main Menu.
2. Highlight Factory Default on the Main Menu screen and press the SELECT button.

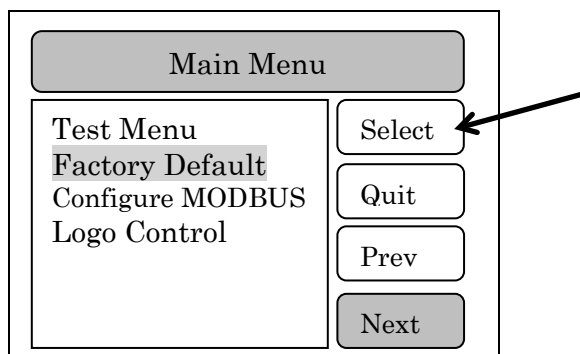

3. Press SELECT key to place the setting in memory and return to the Main Menu screen.

Configure MODBUS

The Steam-trol is supplied with MODBUS communication via a RS485 connection. Some of the MODBUS communication settings can be configured with in the Steam-trol. The user can adjust the MAC Address and the Baud Rate. The communication is fixed to 8 Data Bits, No Parity, and 1 Stop Bits.

The Unit Number is the MAC Address or Address. This address is a unique identification within the MODBUS network. The address can be configured and the range of the address is 1 to 247. This identification number must be provided by the MODBUS network administrator.

The Baud Rate determines the speed of communication. The Baud Rate is adjustable with options of 9600, 19200, and 38400. The Baud Rate of the Steam-trol must use the same Baud Rate as the Building Management System (BMS).

MODBUS Address

To Configure MODBUS address:

1. Press NEXT key three (3) times until Configure MODBUS is displayed on the Main Menu.
2. Highlight Configure MODBUS on the Main Menu screen and press the SELECT button.

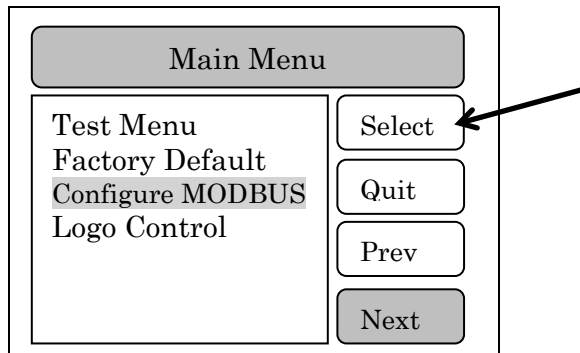

3. The Configure MODBUS screen will appear:
4. Highlight Software Version on the Test Menu screen and press the SELECT button.

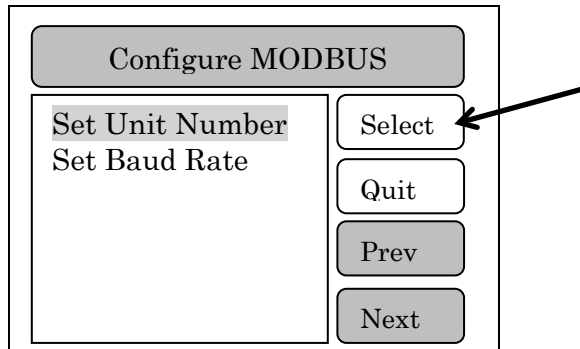

5. The following screen will appear:

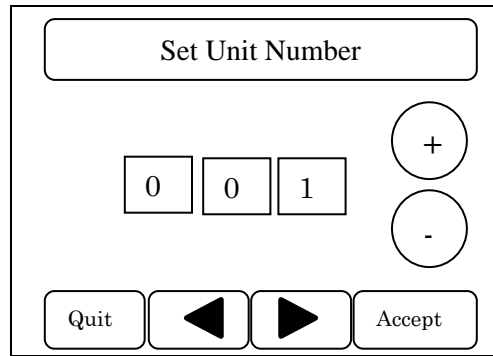

6. Press the + / - keys to scroll through the various address settings until the desired number of address appears on the screen. The address range is 1-247 in 1 unit increments.
7. Press ACCEPT key to place setting in memory and to return to Main Menu.

MODBUS Baud Rate

To Configure MODBUS baud rate:

1. Press NEXT key three (3) times until Configure MODBUS is displayed on the Main Menu.
2. Highlight Configure MODBUS on the Main Menu screen and press the SELECT button.

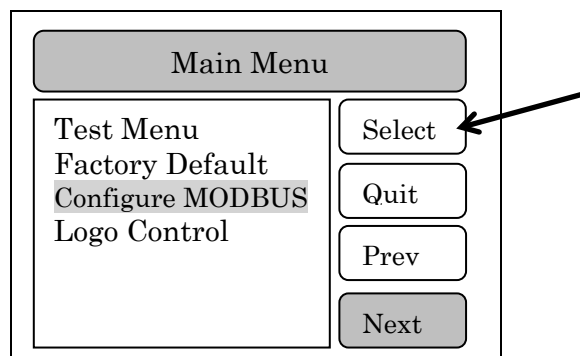

3. The Configure MODBUS screen will appear:

4. Highlight Software Version on the Test Menu screen and press the SELECT button.

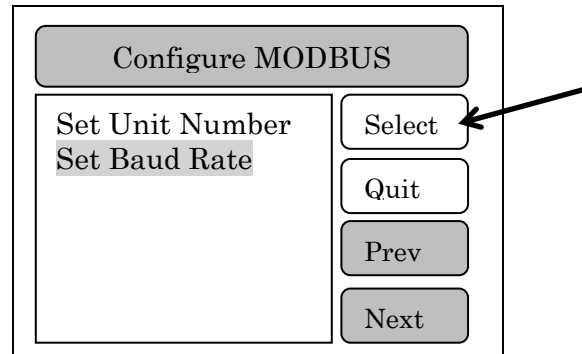

5. The following screen will appear:

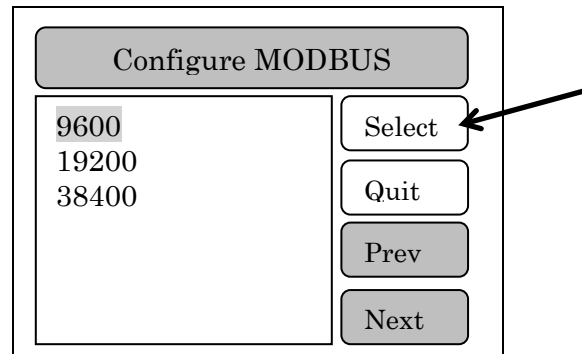

6. The Baud Rate choices are “9600”, “19200”, or “38400”. The Steam-trol control and the BMS must use the same Baud Rate.
7. Press SELECT key to place the setting in memory and return to the Main Menu screen.

Logo Control

This screen allows the user to turn off the logo on the display when the unit is turned on.

To set the logo control:

1. Press NEXT key three (3) times until Logo Control is displayed on the Main Menu.
2. Highlight Logo Control on the Main Menu screen and press the SELECT button.

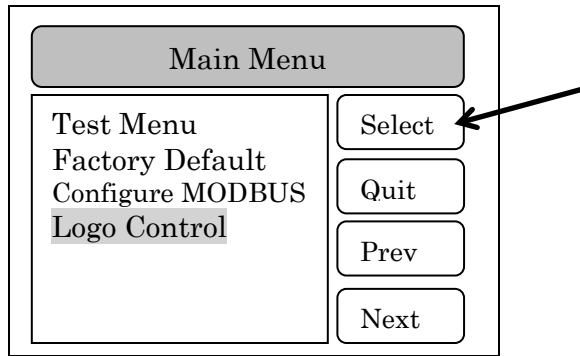

3. The following screen will appear:

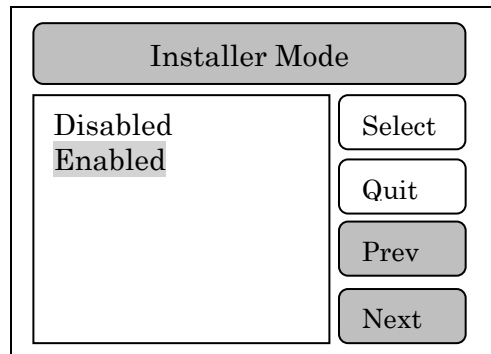

4. Press “Next” key to change Logo Control setting in an increasing direction or press “Prev” key to change the Logo Control in a decreasing direction until the desired Logo Control is highlighted on the screen. The “Logo Control” choices are “Disabled” when the STEAM-TROL will not display the Cemline logo on start-up of the controller or “Enabled” when the Cemline Logo will appear on start up of the controller.
5. The below screen is the logo that will be displayed on when the STEAM-TROL is turned on.



6. Press SELECT key to place the setting in memory and return to the Main Menu screen.

Note: After 90 seconds in any screen “home” screen will be displayed

Terminal Board Layout

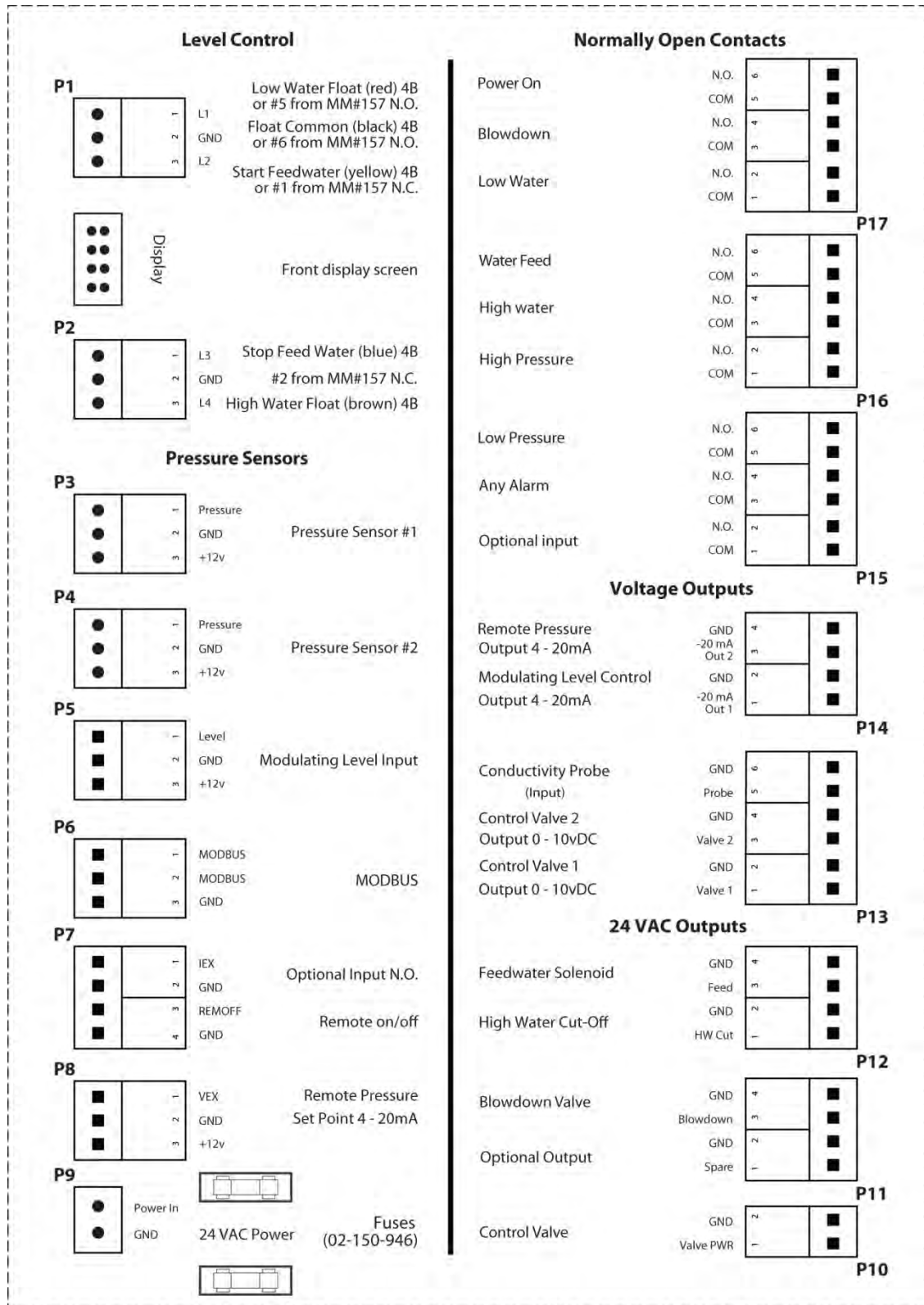

Building Automation System (BAS) Interface

The Cemline STEAM-TROL has built in contacts to interface with the building automation system (BAS).

Remote On-Off:

Terminal block P-7 contacts 3 & 4 is a normally open contact. To wire for Remote On-Off install a switch or relay contacts connecting terminal P-7 contacts 3 and 4. When the Remote On-Off is enabled by closing the circuit between terminal P-7 contacts 3 and 4 the main screen will be as shown below. DISABLED REMOTELY will be displayed in the top banner of the LED display indicating the remote set point has been enabled. When the unit is in a DISABLED REMOTELY MODE, the Steam-trol circuit board will be powered and energized with 24 VAC. Alarm functions will be indicated, however, there will be no voltage output from the circuit board to the control valve, feed water valve, timed-blow down valve, high water cut-off, and optional input/output.

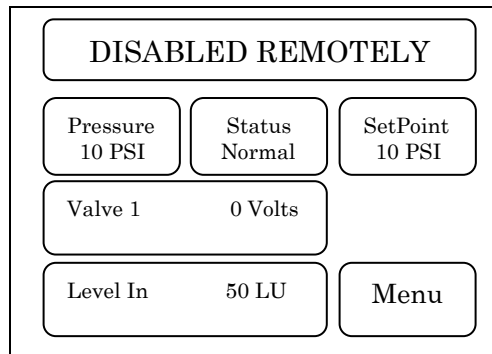

Built in contacts to notify BAS of functions and alarms:

This control allows for simple and reliable interface with the BAS via dry contact to enable the BAS to monitor the following functions from a remote location:

Power ON
Low water
High water
Water feed
High pressure
Low pressure
Blow down operating
Optional input / output
Alarm

Refer to the “Terminal Board Layout” page of this manual for the key to and location of terminal connections to the BAS. Note that all of the function relays give a COM-NO dry contact output. The rating of the dry contacts are 1 amp at 24 VAc or .5 amp at 120 VAC.

- ▼ **CAUTION: Do not connect any voltage above 120 volts across the BAC contacts on terminal block.**

Contact closure as follows:

Power ON	COM - NO contact made when power is on
Low water	COM - NO contact made when in low water condition
High water	COM - NO contact made when high water occurs
Water feed	COM - NO contact made when water is feeding
High pressure	COM - NO contact made when high pressure occurs
Low pressure	COM - NO contact made when low pressure occurs
Blow down operating	COM - NO contact made when blow down occurs
Optional input	COM - NO contact made when optional contact close
Alarm	COM - NO contact made when any alarm occurs

Operating Pressure Read-Out (via a 4-20 mA signal):

Terminal block P-14 contacts 3 & 4 will output a 4 - 20 mA signal. This signal will be scaled to the pressure range of the supplied pressure sensor. To scale the BAS: Determine the the pressure range printed on the body of the supplied sensor and scale the 4 - 20 mA output signal to this range. This range should also be listed in the submittal supplied for the generator.

- ▼ **CAUTION: Terminal block P-14 is connected to an isolated chassis ground. This may interfere with the BAS system. BAS engineering should determine if BAS needs isolation for this signal.**
- ▼ **CAUTION: No current or AC voltage should be applied to terminal P-14 contacts 3 & 4.**

Remote Pressure Set Point (via a 4-20 mA signal):

Terminal block P-8 (contacts 1 & 2) will input a 4-20 mA signal to remotely set the operating temperature of the packaged water heater.

NOTE: In order to use the remote set point the Remote Control must be enabled see page 22 of this manual to read how to enable the remote pressure set point.

- ▼ **CAUTION: When using the remote set point DO NOT set the operating pressure greater than the high limit settings. This will cause improper operation of the unit, with the potential for DANGER by causing alarms to go off and solenoids to close.**
- ▼ **CAUTION: When using the remote set point DO NOT set the operating pressure greater than the relieving pressure the ASME relief valve supplied with the generator. The pressure rating of the relief valve is labeled on the relief valve body. high limit settings. This will cause improper operation of the unit, with the potential for DANGER by causing alarms to go off, solenoids to close, and the relief valve to open.**

- ▼ **CAUTION: Once the Remote Control is Enabled the local setting is no longer used unless the Remote Control has been Disabled.**

The remote pressure set point of the pressure of the steam generator can be set between different ranges depending upon the pressure sensor used on the unfired steam generator. Cemline offers four possible pressure sensor ranges: 0 – 30, 0 – 60, 0 – 150, and 0 – 300 psi. When using 0 and 30 PSI using a 4 – 20 mA signal whereby 4 mA= 0 PSI and 20 mA = 30 PSI. See the table below for all pressure sensors and the equivalent 4 – 20 mA input settings.

Pressure Sensor	4 mA	20 mA
0 – 30 PSI	0	30
0 – 50 PSI	0	50
0 – 60 PSI	0	60
0 – 100 PSI	0	100
0 - 150 PSI	0	150
0 – 200 PSI	0	200

When the remote set point is enabled the main screen will be as shown below. REMOTE SETPOINT will be displayed in the top banner of the LED display indicating the remote set point has been enabled.

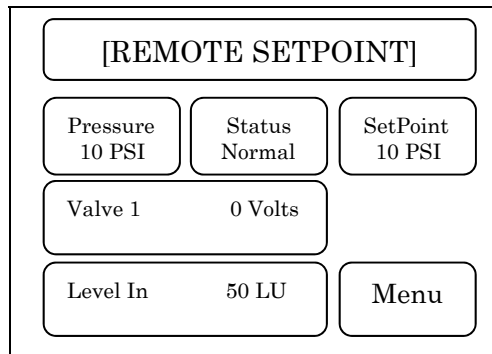

NOTE: If no mA signal is applied to the remote set point the set point pressure will default to 0 PSI.

- ▼ **CAUTION: Terminal block P-8 is connected to an isolated chassis ground. This may interfere with the BAS system. BAS engineering should determine if BAS needs isolation for this signal.**
- ▼ **CAUTION: No AC voltage should be applied to terminal block P-8 contacts 1 & 2.**

MODBUS COMMUNICATION

The Steam-trol is supplied with MODBUS RTU communication via a RS485 connection. Some of the MODBUS communication settings can be configured within the Steam-trol. The user can adjust the MAC Address and the Baud Rate. The communication is fixed to 8 Data Bits, No Parity, and 1 Stop Bits.

The Unit Number is the MAC Address or Address. This address is a unique identification within the MODBUS network. The address can be configured and the range of the address is 1 to 247. This identification number must be provided by the MODBUS network administrator. See page 34 of this manual for instructions on configuring the Unit Number.

The Baud Rate determines the speed of communication. The Baud Rate is adjustable with options of 9600, 19200, and 38400. The Baud Rate of the Steam-trol must use the same Baud Rate as the Building Management System (BMS). See page 35 of this manual for instructions on configuring the Baud Rate.

The MODBUS should be wired using 18 AWG Twisted-Pair cable. The cable length should not exceed 3500 feet. A longer cable length may require a lower Baud Rate. Terminal Block P-6 Contacts 1 through 3 are the MODBUS RTU connections. Contact 1 is positive (+), Contact 2 is negative (-), and Contact 3 is Ground. Please verify that the (+) and (-) polarity is correct. The Ground RS485 terminal P6 contact 3 must be connected to the BMS RS485 Ground.

The Steam-trol MODBUS Variable List can be found on page 43 of this manual. The conditions that are being supplied are outputs only no inputs. Therefore, in order to remotely set the pressure a 4 – 20 mA signal is required. Please see page 40 of this manual for instructions on remote pressure setting.

Steam-trol MODBUS Variable List

Register	Condition	Value
400002	Any Alarm	1 = Alarm / 0 = No Alarm
400003	Low Water	1 = Low Water / 0 = No Low Water
400004	High Water	1 = High Water / 0 = No High Water
400005	High Pressure	1 = High Pressure / 0 = No High Pressure
400006	Low Pressure	1 = Low Pressure / 0 = No Low Pressure
400007	Pressure Sensor 1 Loss	1 = Pressure Sensor 1 Loss, 0 = No Pressure Sensor 1 Loss
400008	Pressure Sensor 2 Loss	1 = Pressure Sensor 2 Loss / 0 = No Pressure Sensor 2 Loss
400009	Pressure Differential Error	1 = Pressure Differential Alarm / 0 = No Pressure Differential Alarm
400010	Power On	1 = Power On / 0 = Power Off
400011	BlowDown Occurring	1 = Blowdown On / 0 = Blowdown Off
400012	Water Feed Occuring	1 = Water Feed On / 0 = Feed Water Off
400013	Optional Input	1 = Optional Input On / 0 = Optional Input Off
400014	Disabled Remotely	1 = Disabled Remotely / 0 = Not Disabled Remotely
400015	Pressure Sensor 1 Value	Value is Pressure 1 Reading (PSI)
400016	Pressure Sensor 2 Value	Value is Pressure 2 Reading (PSI)
400017	Level Control	
	4 Level Type	5 = All Floats in Down Position (Low Water Condition, Water Feed On)
		30 = Low water float in the up position (Low Water Condition, Water Feed On)
		50 = Start Feedwater Float in the Up position (Water Feed On)
		60 = Stop Feedwater Float in the Up position (Water Feed Off)
		95 = High Water float in the Up Position (High Water Condition, Water Feed Off)
	2 Level Type	5 = Float Down (Low Water Condition)
		50 = Float Rises 1st Position (Water Feed On)
		60 = Float Rises 2nd Position (Water Feed Off)
		95 = High Water Conductivity Probe Covered (High Water Condition, Water Feed Off)
	Analog Type	Value = Value of the Current from Level Control (4 - 20 mA)
400018	Voltage Out To Control Valve 1	Value is Voltage out to Valve 1 (VDC)
400019	Voltage Out to Control Valve 2	Value is Voltage out to Valve 2 (VDC)
400020	Setpoint Value	Value is Setpoint Value (PSI)

Wiring Diagram – Self-Contained Temperature Pilot Operated Control Valves

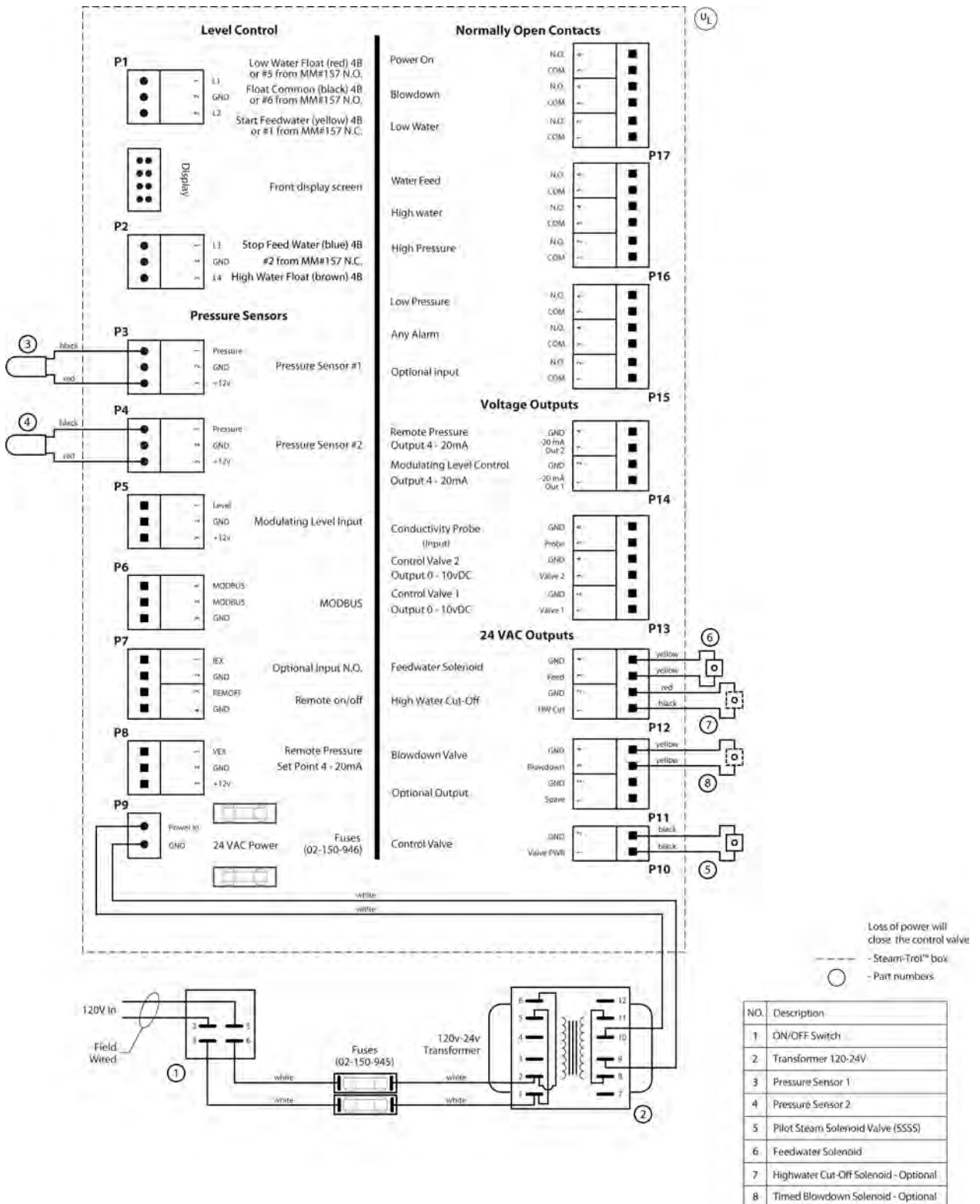

Wiring Diagram – Pneumatic Operated Control Valves with I-P Transducer

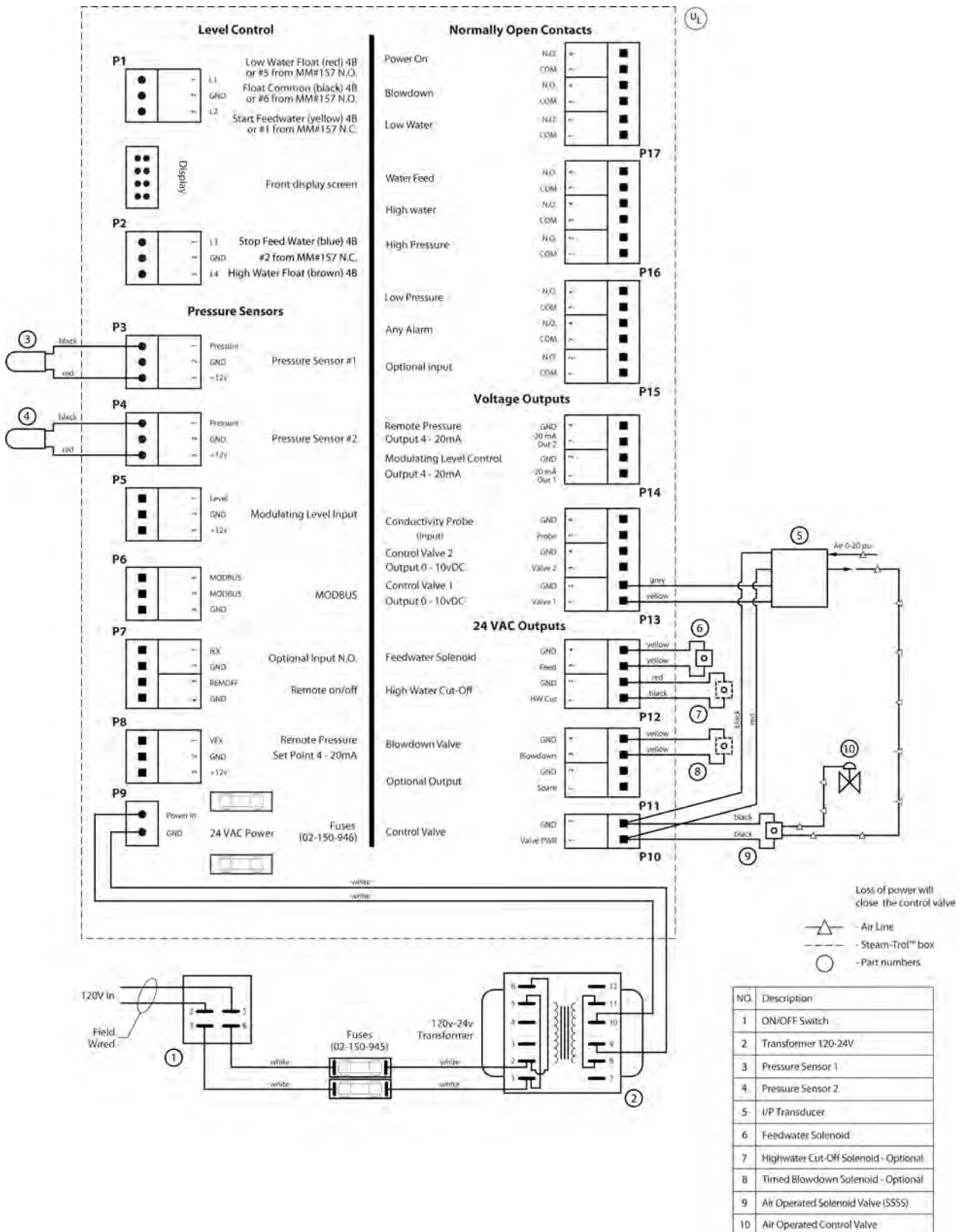

Wiring Diagram – Warren Controls Valve - ARIA Actuator (After August 2024)

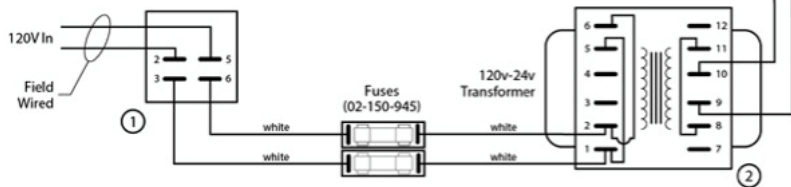
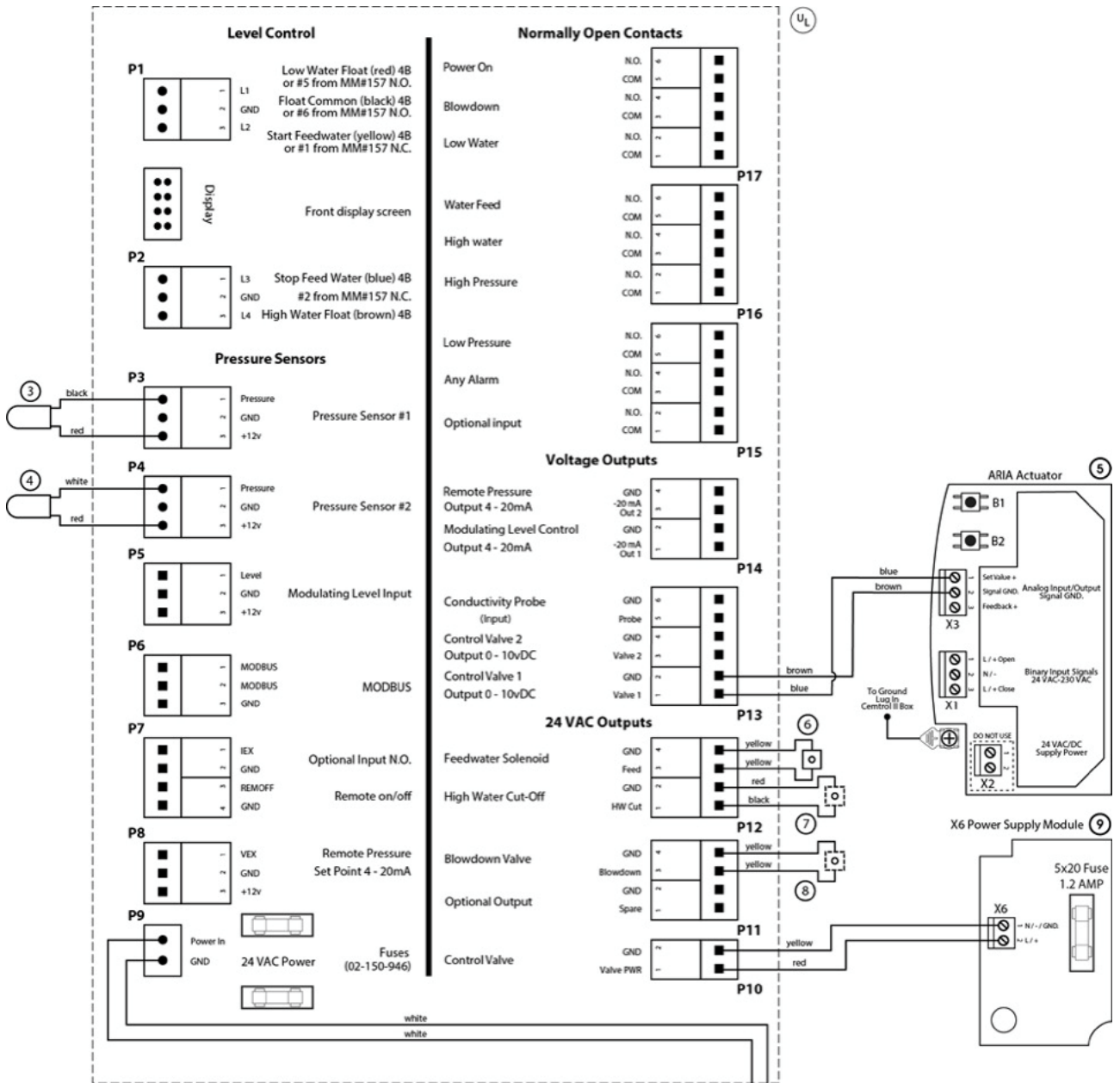

--- Steam-Trol™ box
○ Part numbers

NO.	Description
1	ON/OFF Switch
2	Transformer 120-24V
3	Pressure Sensor 1
4	Pressure Sensor 2
5	Valve Module
6	Feedwater Solenoid
7	Highwater Cut-Off Solenoid - Optional
8	Timed Blowdown Solenoid - Optional
9	X6 Power Supply Module

Wiring Diagram – Warren Controls Valve - ARIA Actuator (Before August 2024)

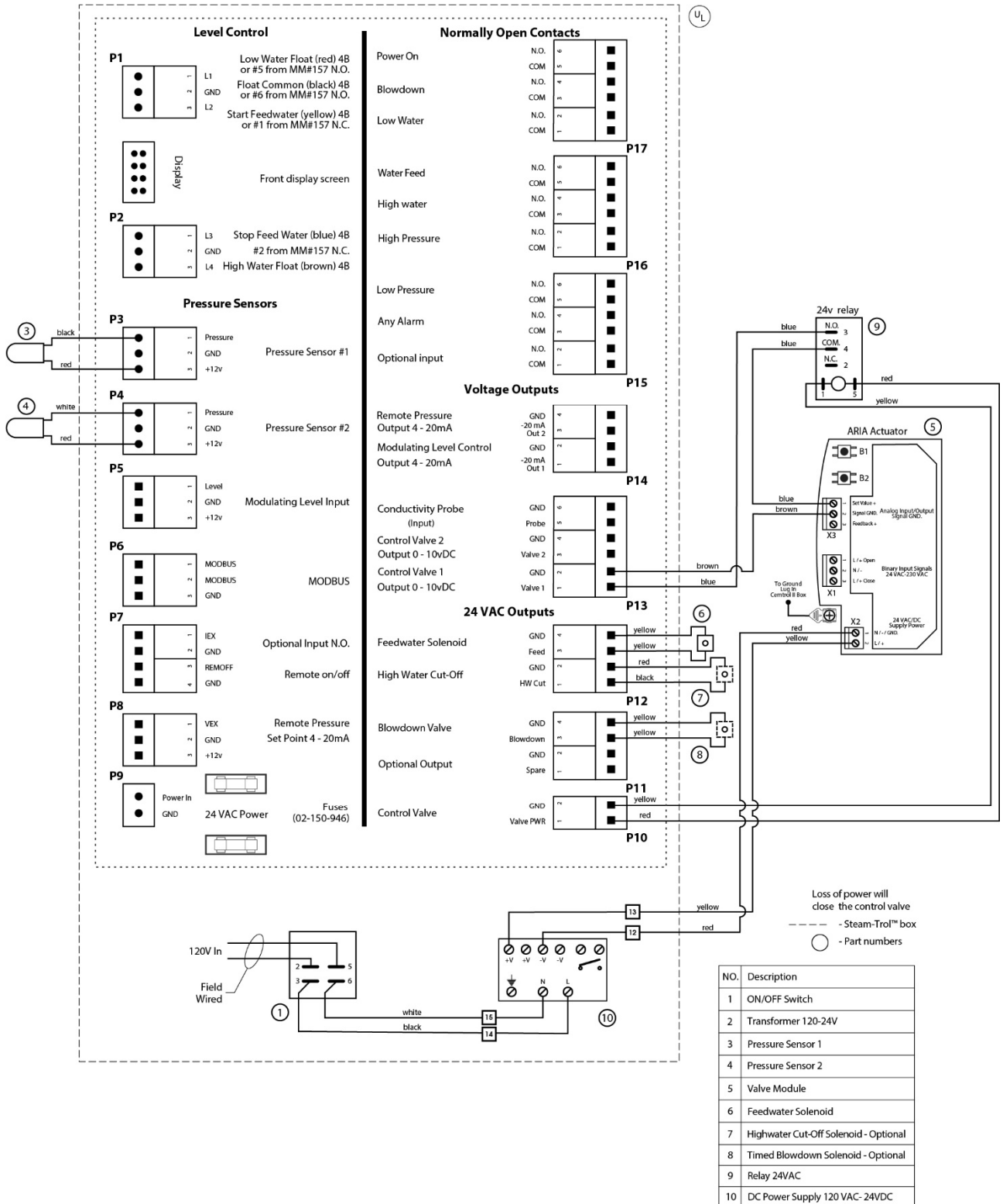

Wiring Diagram – MXG and MXF Valves

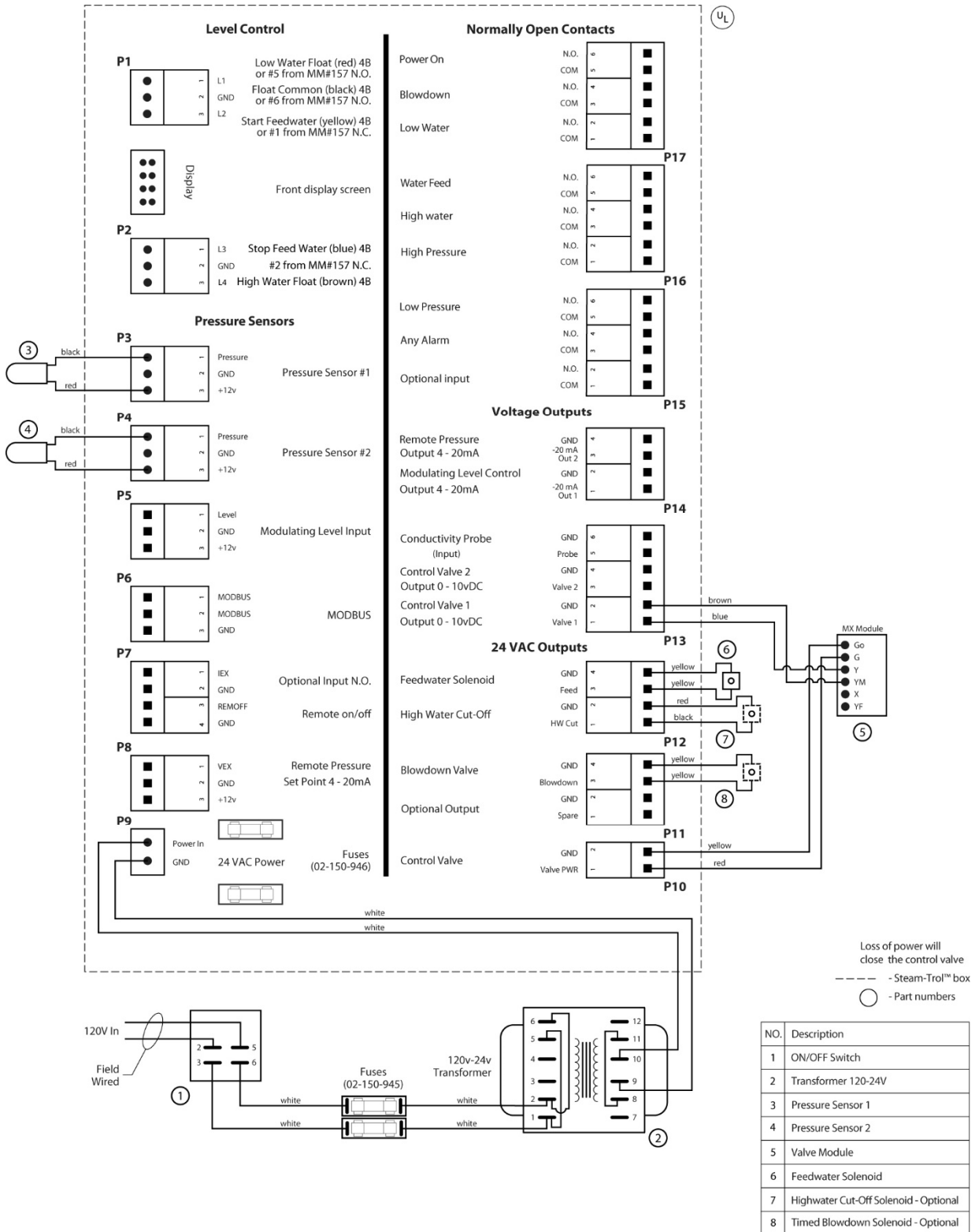

NO.	Description
1	ON/OFF Switch
2	Transformer 120-24V
3	Pressure Sensor 1
4	Pressure Sensor 2
5	Valve Module
6	Feedwater Solenoid
7	Highwater Cut-Off Solenoid - Optional
8	Timed Blowdown Solenoid - Optional

Wiring Diagram – M2H and M3P Valves

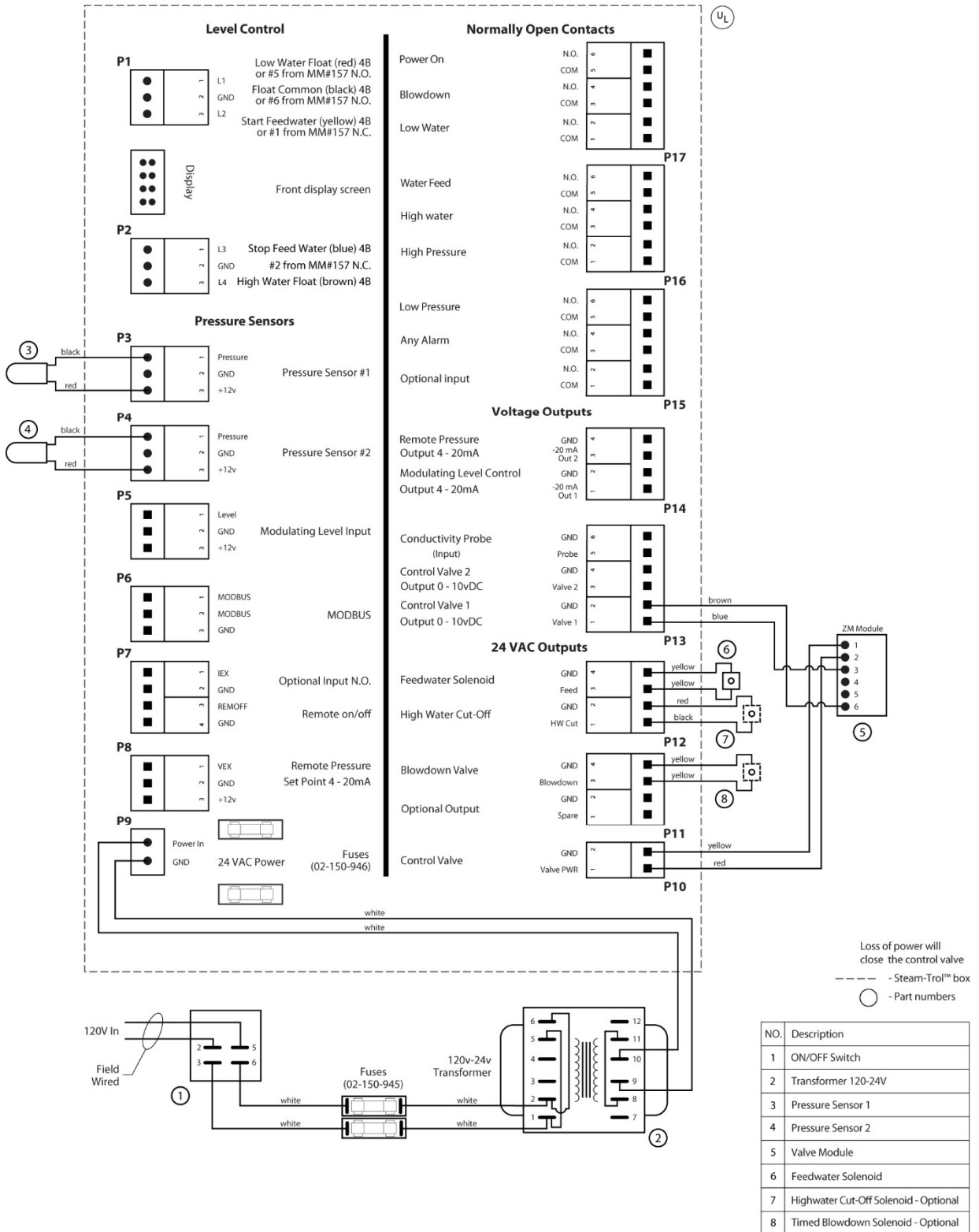

Wiring Diagram – MVF Valves

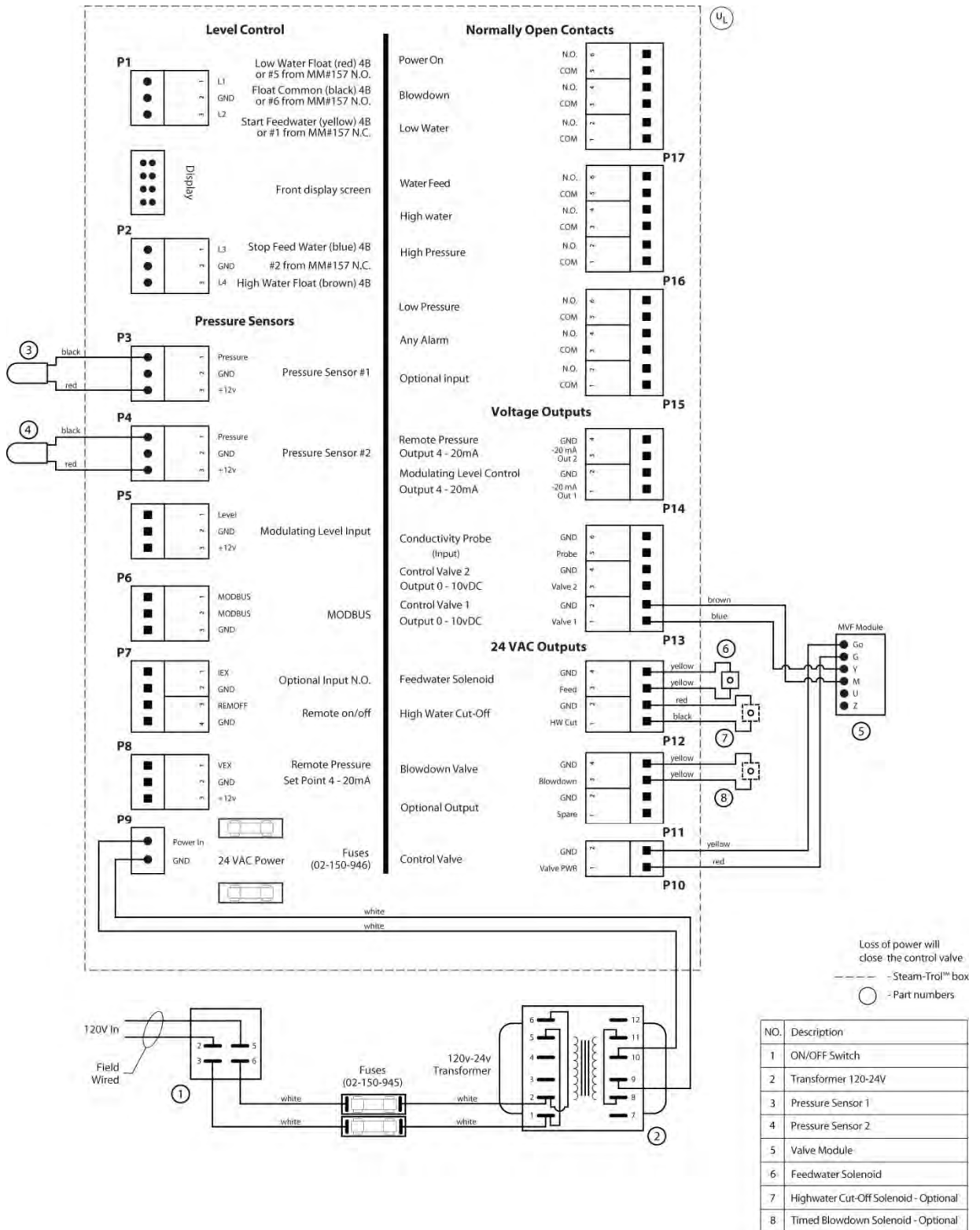

MXG and MXF Valve Information

The MXG and MXF valves can be configured for linear and equal percentage operation. Factory setting is equal percentage.

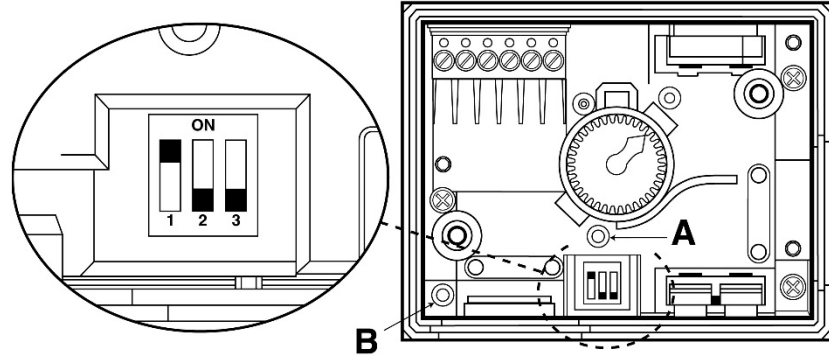

Switch	OFF	ON
1	Characteristic Linear	Equal percentage *
2	Control signal — must be in the OFF position	
3	Volts or mA — must be in the OFF position	

Valve Calibration

The MXG and MXF valves are factory-calibrated at 0% and 100% stroke. When commissioning the valves, however, (especially under extreme conditions of use) there may still be some leakage via control path A → AB (below, and marked on the valve). In this case, the valve can be recalibrated simply and quickly as follows. Remove the screws from the top of the electrical housing on the control valve and remove the cover. Using a pointed implement (2mm diameter) to operate the button in the opening [A] in the terminal housing. While recalibration is in progress, the LED [B] in the electronics module will flash green for approximately 10 seconds. The valve will be briefly closed and fully opened.

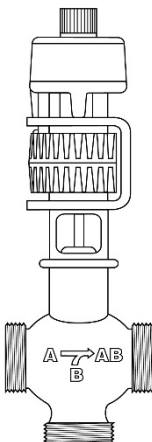

The two-color LED display [B] indicating operating status can be viewed by opening the cover of the electronics module.

LED green	On continuously	Automatic mode: 'Auto' (normal, no faults)
	Flashing	<ul style="list-style-type: none"> – Mechanically set to 'Manual' – Mechanically set to 'Off' – Currently in 'Calibration' mode
LED red	On continuously	<ul style="list-style-type: none"> – General fault – General calibration error – Micro controller fault
	Flashing	– Faulty AC 24 V supply (e.g. too low)
	LED	Off

As a general rule, the LED can assume only the states shown above (continuously red or green, flashing red or green, or off).

Warning

The control valve has a hand wheel knob on the top of the valve (see diagram below). This control knob must be placed into the automatic position (AUTO). The AUTO position allows automatic control of the valve to occur. By placing the hand wheel in the OFF position the valve will not close. **Do not place the wheel in the manual position.** By placing the wheel in the manual position prevents the control program to function correctly and is dangerous to the operation of the unit. **The hand wheel knob must be in the auto position.**

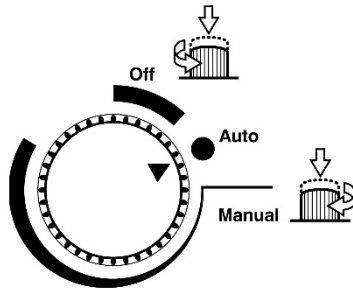

M3P and M2H Valve Information

Valve Calibration

The M3P and M2H valves are factory-calibrated at 0% and 100% stroke. When commissioning the valves, however, (especially under extreme conditions of use) there may still be some leakage via control path 1 → 2 for the M2H and 1 → 3 for the M3P (*see below*, and marked on the valve) with a 0% stroke control signal (DC 0V, DC 4 mA or DC 2 V). In this case, the valve can be recalibrated simply and quickly as follows. Remove the left screw of the electronic module also known as the ZM module. Use a pointed implement (2mm diameter) or a screwdriver No. 0 or 1 to push in the switch in the electronics module (*see below*). While recalibration is in progress, the LED in the electronics module will flash green for approximately 10 seconds. The valve will be briefly closed and fully opened, full stroke is maintained for 1 to 3 seconds and the valve closes again. The valve will then go to the position which corresponds to the position signal. If the LED continues to flash after 10 seconds there was an error in operation during the calibration process or there is another fault.

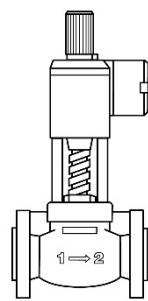

M2H

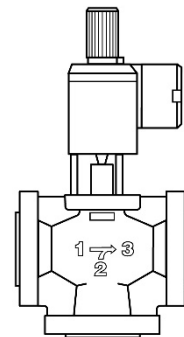

M3P

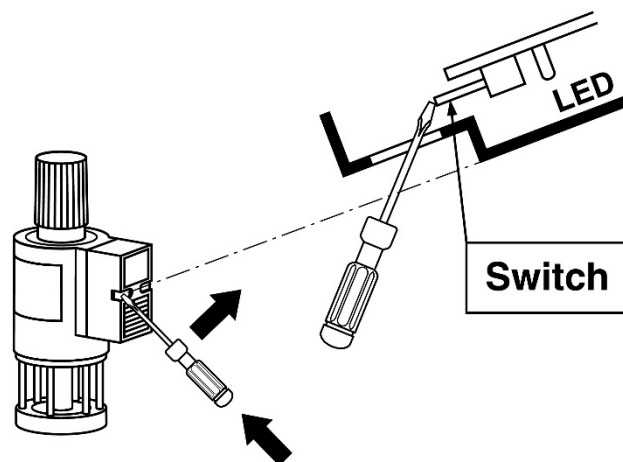

MVF Valve Information

The MVF valve can be configured for linear and equal percentage operation. Factory setting is equal percentage.

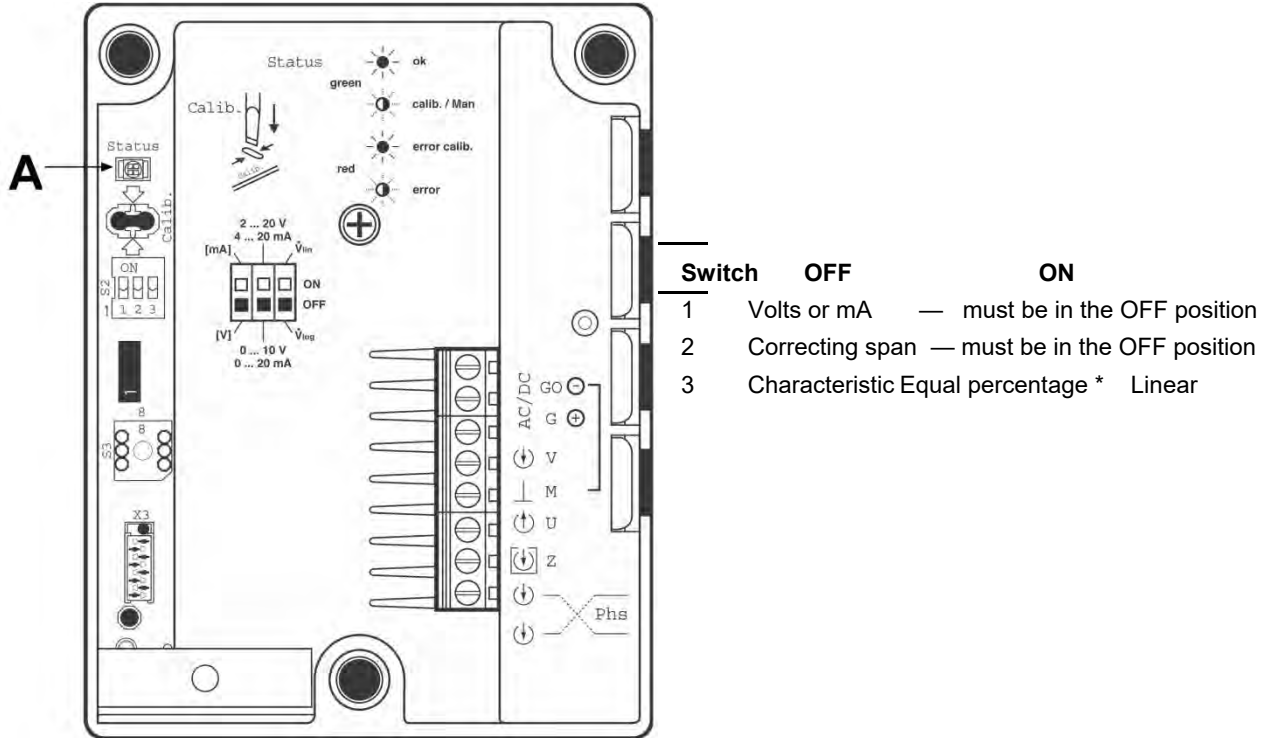

Valve Calibration

The MVF valves are factory-calibrated at 0% and 100% stroke. When commissioning the valves, however, (especially under extreme conditions of use) there may still be some leakage via control path A → AB and the valve's electronics must be recalibrated. To recalibrate, the hand wheel must be set into the automatic position (AUTO).

Remove the screws from the top of the electrical housing on the control valve and remove the cover. The printed circuit board has a slot for calibration (see diagram below). Calibrate by bridging the contacts located behind the slot on the printed circuit board, using a screwdriver. The valve will then travel across the full stroke to store the end positions. While recalibration is in progress, the LED [A] in the electronics module will flash green for approximately 10 seconds. The valve will be briefly closed and fully opened. The valve will then go to the position which corresponds to the position signal. If the LED continues to flash after 10 seconds there was an error in operation during the calibration process or there is another fault.

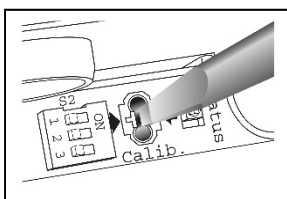

The two-color LED display [A] indicating operating status can be viewed by opening the cover of the electronics module.

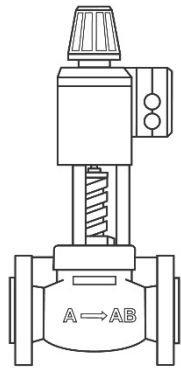
 <p style="text-align: center;">MVF</p>		Indication	Operating State, Function	Remarks, Troubleshooting
	Green	Lit	Control mode	Normal operation; everything OK.
		Flashing	Calibration In manual control	Wait until calibration is finished (green or red LED will be lit) Hand wheel in Man or Off position
	Red	Lit	Calibration error Internal error	Recalibrate (bridge contacts behind the calibration slot) Replace electronics module
		Flashing	Main fault DC Supply - / +	Check electric main network (outside the frequency or voltage range); VDC supply +/- connection polarity
	Both	Dark	No power supply Electronics faulty	Check electric main network, check wiring Replace electronics module

Warning

The control valve has a hand wheel knob on the top of the valve (see diagram below). This control knob must be placed into the automatic position (AUTO). The AUTO position allows automatic control of the valve to occur. By placing the hand wheel in the OFF position the valve will not close. **Do not place the wheel in the manual position.** By placing the wheel in the manual position prevents the control program to function correctly and is dangerous to the operation of the unit. **The hand wheel knob must be in the auto position.**

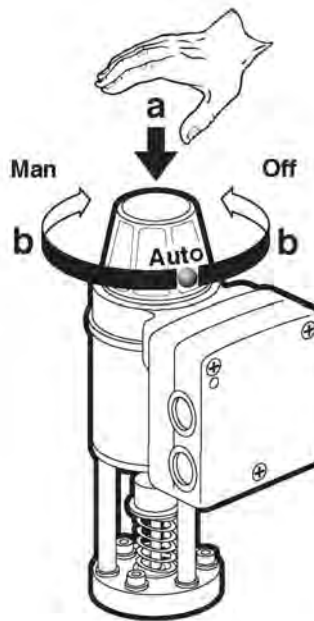

General Valve Information

The valve is factory assembled and does not require repacking or other periodic service.

Testing

1. Turn the power off to the unit.
2. Remove the control module from the valve by loosening the two mounting screws.
3. Measure the resistance between the two terminals indicated on the drawing on page 36. Also see chart on page 36 for resistance for valve coil. Look on valve for the model number that corresponds with the chart.
4. Check one of above terminals to ground. The resistance should be infinite.
5. Measure the voltage at 24 volt transformer between points 7 and 12 as seen on the wiring diagram from page 7.
6. Reconnect the control module.
7. Reconnect the power to the CEM-TROL.

Magnetic Coil Resistance Information

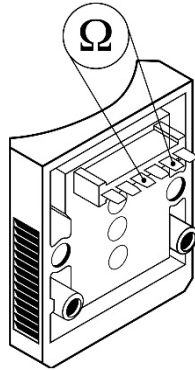

1) Magnetic Coil Resistance (Kl. 7+8)

Valve Model	Actuator Coil
	Resistance (Ω)
M2H15F	21
M2H20FY	21
M2H25FY	21
M2H32FY	15.3
M2H40FY	10
M2H50FY	10
M3P80FY	5.187
M3P100FY	3.34

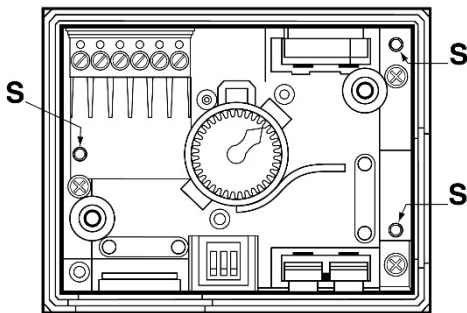

Diagram A

1. Remove the screws from the top of the electrical housing on the control valve and remove the cover.
2. Using a 3 mm Allen wrench remove the 3 Allen head screws (S) which hold the electronic module to the control valve housing (see diagram A).
3. Measure the magnetic coil resistance across the two exposed terminals (see diagram B) and compare the resistance to the chart below.
4. Carefully re-install the electronic control module and cover.

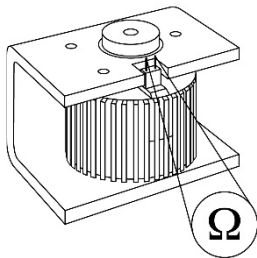

Diagram B

Valve Model	Actuator Coil
	Resistance (Ω)
MXF461.15	9.2
MXF461.65	4.87
MXG461.25	9.2
MXG461.32	9.2
MXG461.40	5.55
MXG461.50	5.55
MXG461.15	9.2

Magnetic Coil Resistance
(Stem stroke length cannot be measured)

Warren Controls ARIA Valve Information

- ▼ For Complete information on the Warren Controls ARIA & ILEA Actuators see the Warren Installation, Operation, & Maintenance Manual supplied with the unit. The IOM manual is supplied with the unit, otherwise the manual can be found online at www.warrencontrols.com.

Notes



P. O. Box 55, Cheswick, PA, 15024
Phone: (724) 274-5430 • FAX (724) 274-5448
www.cemline.com
